



2º Encuentro de
Ciencia, Tecnología e Ingeniería
de Estudiantes de Posgrado
FACULTAD DE INGENIERÍA CIVIL

11 al 13
OCTUBRE | 2021

UNIVERSIDAD AUTÓNOMA DE NUEVO LEÓN

Aprendiendo con los Accidentes

Colapsos de Miami/USA y otros

PhD
do Laboratório de Pesquisa ao Canteiro de Obras

Paulo Helene
Director PhD Engenharia
Consejero CNTU, SIURB y SEESP
Ex-Presidente ALCONPAT Internacional
Prof. Catedrático Universidad de São Paulo
Presidente Instituto Brasileiro del Concreto IBRACON
Member fib(CEB-FIP) Model Code for Service Life Design

UANL 13 de octubre de 2021 Nuevo León/MX

1



National Institute of Standards and Technology (NIST)

- NIST, anteriormente *The National Bureau of Standards*, es una agencia del gobierno, no regulatoria, perteneciente al Departamento de Comercio de los Estados Unidos.
- NCST *National Construction Safety Team*, es un grupo bajo NIST creado el 1 de octubre de 2002 por el presidente George W. Bush para realizar inspecciones y diagnóstico en edificios colapsados, pero no tiene la función de indicar un culpable.
- El colapso de *Champlain Towers South* es la quinta investigación del grupo NCST

NIST, 2021. Disponible em: <https://www.nist.gov/disaster-failure-studies/champlain-towers-south-collapse>. Acceso em: 07, Outubro, 2021.
Surface, 2021. Disponible em: <https://surfside.one/public-records-search/>. Acceso em: 07, Outubro, 2021.

2

World Trade Center *Terrorismo*

- Colapso 11/09/2001
- Reporto final Set. 2005 e Nov. 2008
- 2.996 muertes
- Lower Manhattan, Nova Iorque, Estados Unidos
- Diagnóstico: calor del fuego sobre el acero



<https://www.nist.gov/el/final-reports-nist-world-trade-center-disaster-investigation>

3



11 de Setembro de 2001

4

Resistencia y Estabilidad

Las mediciones indicaron que el impacto del Boeing 767-200 sometió al edificio a vibraciones similares a las de un terremoto de índice Richter a escala 2.4

Esta vibración inducida tenía una amplitud del orden de la mitad del máximo considerado por el efecto del viento.

5

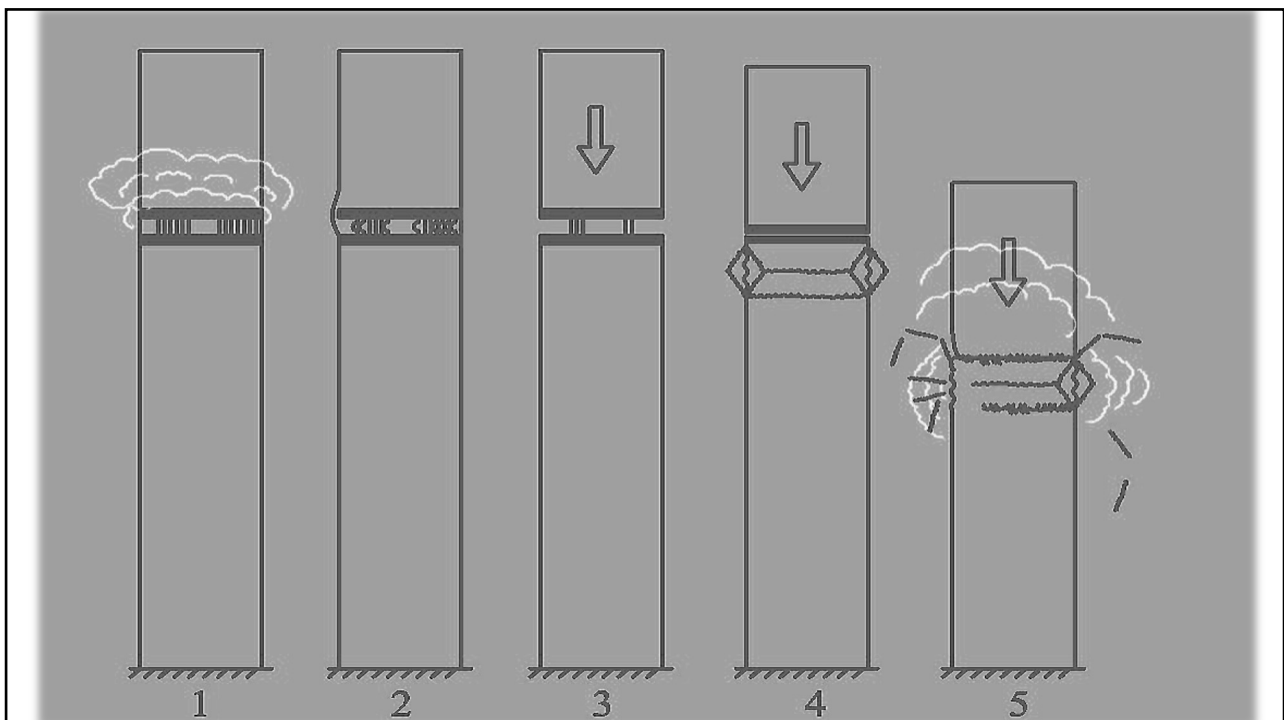

6



Station Nightclub *Incêndio*

- Accidente 20/02/2003
- Informe final: junio de 2005
- 100 muertos y más de 187 heridos
- West Warwick, Rhode Island, EUA

<https://www.nist.gov/publications/report-technical-investigation-station-nightclub-fire-appendices-nist-ncstar-2-volume-2>

<https://www.nist.gov/publications/report-technical-investigation-station-nightclub-fire-nist-ncstar-2-volume-1>

7



Edifício Wilton Paes de Almeida 2018 8 muertes 50 años

8



9



10

Lecciones Aprendidas (*website:phd.eng.br*)

1. **ATP, revisar el diseño estructural a altas temperaturas (Δ de 250⁰ C);**
2. **Archivar proyecto ejecutivo estructural o proyecto "as built" en nubes publicas;**
3. **Inspección periódica; Protección pasiva y activa obligatoria; Redundancia y robustez en el proyecto estructural**

chrome-extension://efaidnbmnnnibpcajpcgclefindmkaj/viewer.html?pdfurl=http%3A%2F%2Fwww.phd.eng.br%2Fwp-content%2Fuploads%2F2019%2F04%2F19.04.30ParecerCompletoPaesAlmeida_final-compactado.pdf&cflen=13968403&chunk=true

11



12

NIST encourages members of the public to submit any information, including video, photos or other documentation

- ✓ June 24, 2021, Champlain Towers South, 12-floor condominium in Surfside, Florida, at 1:30 a.m.
- ✓ June 25, NIST began a team of six scientists and engineers to collect firsthand information on the collapse.
- ✓ June 30 decided full technical investigation of the collapse by National Construction Safety Team (NCST) Act
- ✓ NCST's work will not interfere with the ongoing search-and-rescue operation at the scene of the collapse.
- ✓ NCST's role is not to determine any culpability.
- ✓ NCST investigation is to determine the technical diagnose and cause of the collapse and, learning from that, to recommend changes to building codes, standards and practices, and appropriate actions to improve the structural safety of buildings.
- ✓ NCST investigations are thorough and typically take years to complete.
- ✓ NCST team will provide updates on its progress to, at its regular meetings, which are open to the public.

13

Robert Stephenson en su discurso inaugural a la presidencia del Instituto de Ingenieros Civiles de Gran Bretaña en 1856:

"Tengo la esperanza de que todos los accidentes y problemas que han ocurrido en los últimos años sean registrados y revelados.

Nada es tan instructivo para los jóvenes ingenieros como el estudio de los accidentes y su corrección.

El diagnóstico de estos accidentes, la comprensión de los mecanismos de ocurrencia, es más valioso que la descripción de trabajos exitosos.

Los ingenieros experimentados también aprenden de estas enseñanzas y lecciones de accidentes que incluso pueden ocurrir en sus propios trabajos.

Con este noble objetivo de enseñanza, nos proponemos a catalogar estos problemas en los archivos de esta reconocida institución".

14

Inspecciones del NCST/NIST Torres Champlain Sur

- Análisis del suelo y roca
- Análisis del agua subterránea
- Rayos láser (Lidar) para mapear la ubicación
- Drones para recoger imágenes y registros
- Velocidad de pulso ultrasónica (VPU) para analizar el hormigón de la estructura
- Acelerómetros para medir la vibración de Champlain Towers North (referencia)



15



Inspecciones

- Se recogieron cerca de 200 elementos constructivos
- Las recomendaciones finales estarán disponibles 90 días después del final de las investigaciones.

16

National Construction Safety Team (NCST)

Equipo Nacional de Seguridad en la Construcción

Equipo Multidisciplinar

13 miembros, PhD



17

Judith Mitrani-Reiser

- Lidera la investigación de Champlain Towers South (*habla fluente inglés y español*)
- Jefe de la división de Materiales Estructurales y Sistemas del Laboratorio de Ingeniería del NIST
- Universidad Civil de Ingeniería de Florida
- Maestría en la Universidad de California en Berkeley
- PhD mecánica aplicada do California Institute of Technology



18

Glenn Bell



- 45 años de experiencia en proyectos de rehabilitación e investigación de fallas
- Há investigado los colapsos:
 - Pasarela del Hyatt Regency Hotel en Kansas City en 1981
 - Las Torres 1 y 2 del World Trade Center
 - Há evaluado los efectos de las reacciones químicas álcali-sílice en el hormigón de la central nuclear de la estación Seabrook
- Ingeniero civil en la Universidad de Tufts
- MSc & PhD ingeniería estructural y mecánica estructural por la Universidad de California en Berkeley

19



David Goodwin → químico, PhD



Jim Harris → Standars históricas vigentes a la época de la construcción y diseño estructural, PhD



Youssef Hashash → geotécnia, PhD



Ken Hover → ciência de los materiales, PhD

20

	Scott Jones → ciência de los materiales, PhD	
	Jack Moehle → ingeniero estructural, PhD	
	Sissy Nikolaou → geotecnia, PhD	
	Long Phan → constructor e estruturas, PhD	
	Fahim Sadek → inspección estructural, PhD	
	Chris Segura → estruturas, PhD	
	Jonathan Weigand → estruturas, PhD	

21



22

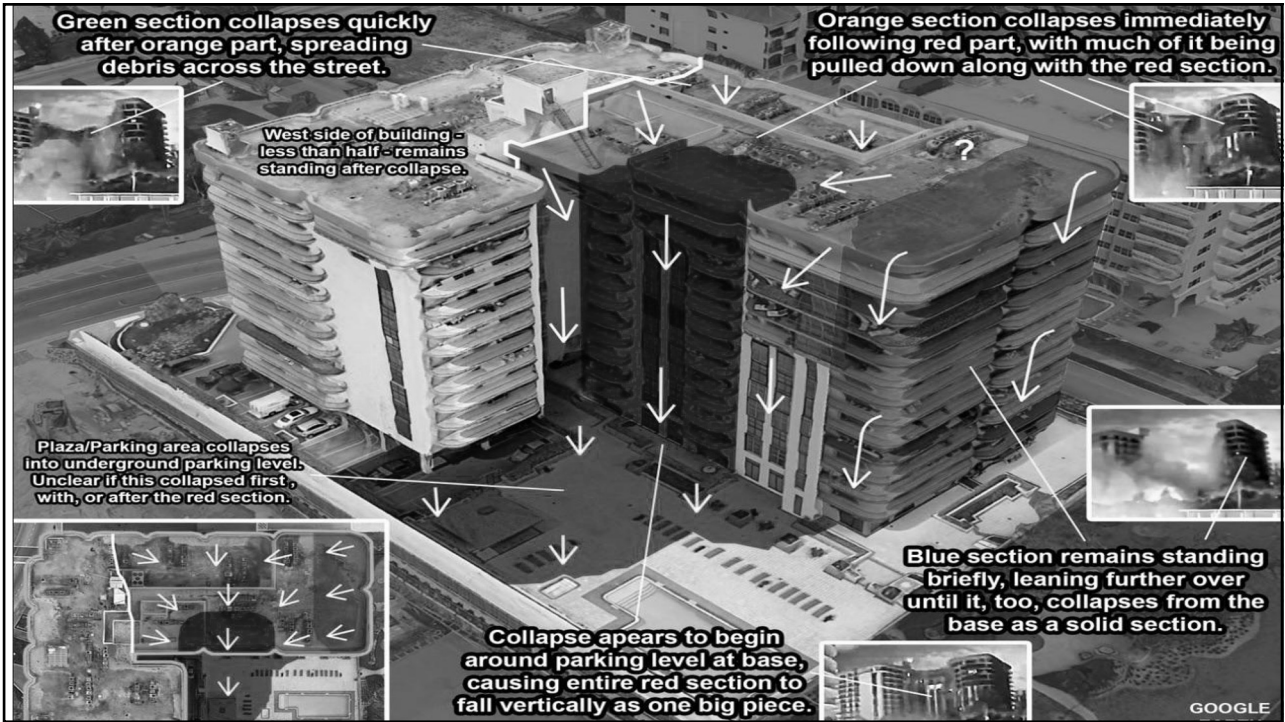

23



24

Hay consenso

*Empezó con el punzionamiento
de la losa del área de recreación*

Preguntas, Dudas ?

1. *Cual fue el gatillo, tras 40 años ?*
2. *Como propagó a las torres ?*

25



26

Pileta Centro Esportivo

Prueba de Carga realizada en junio de 2017

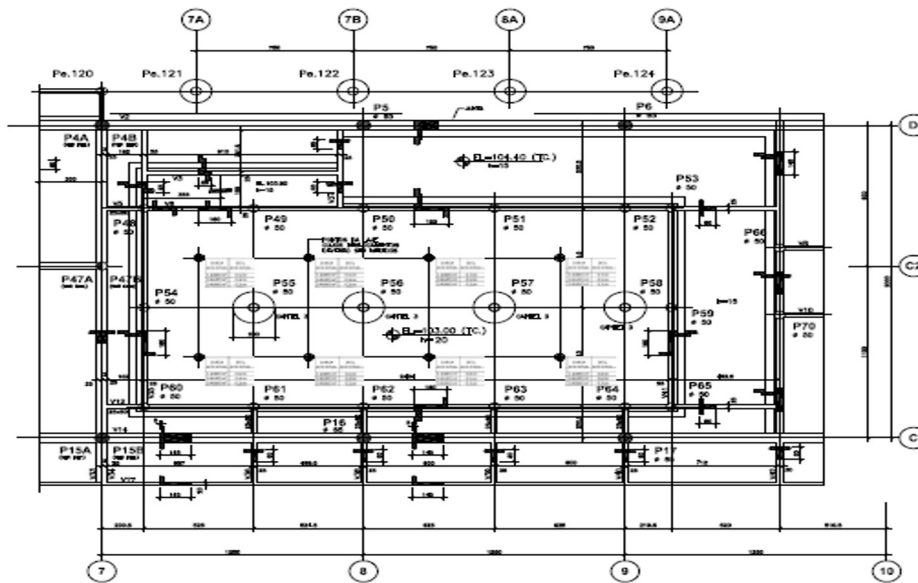

27

Problema

La revisión del diseño estructural, ATP (análise técnica del proyecto estructural) apuntó que hay problemas de cálculo en la losa de fondo.

Fue decidido una prueba de carga



28



29



30



31



32



33



34

Paulo Helene

MANUAL

PARA REPARO, REFORÇO E PROTEÇÃO DE ESTRUTURAS DE CONCRETO

Projeto de Divulgação Tecnológica

PINI Editora

FOSROC

Punção

Manifestação Típica



35

Fissuração: Carbonatação y Cloruro

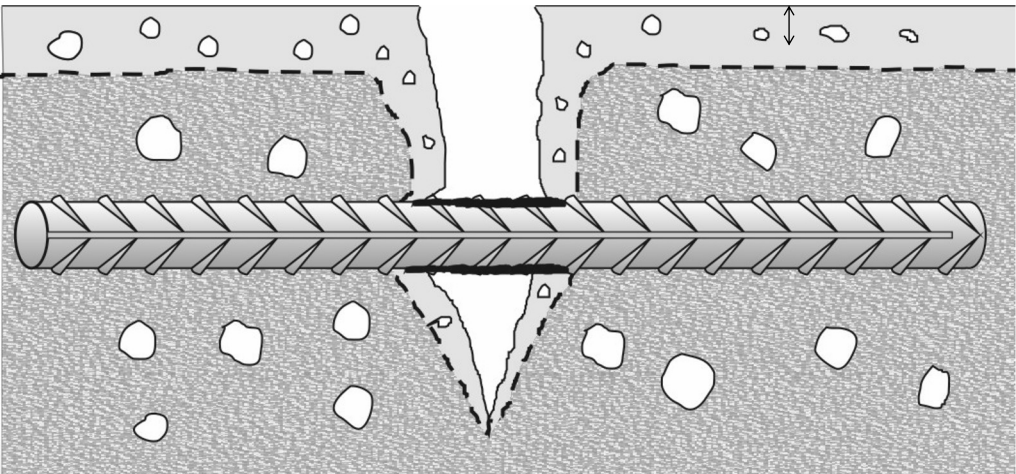

espesura carbonatada

w_k piezas a flexion $\gamma_F = 1$

36

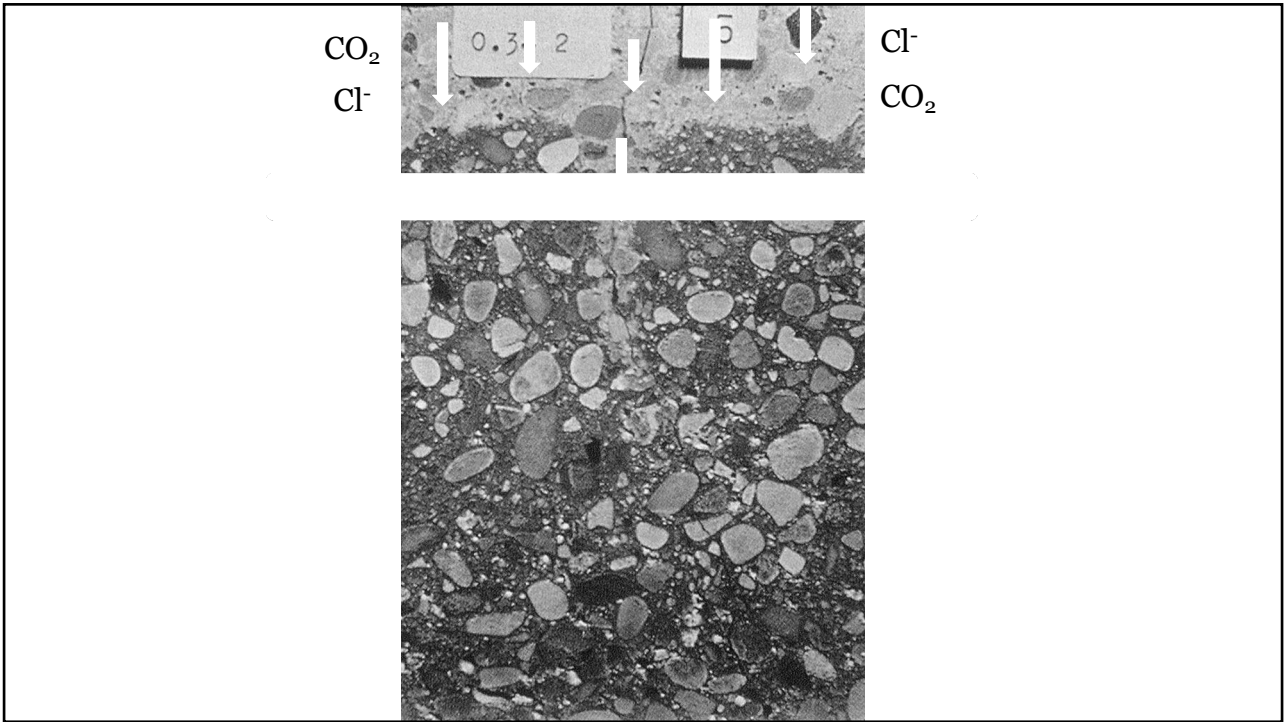

37

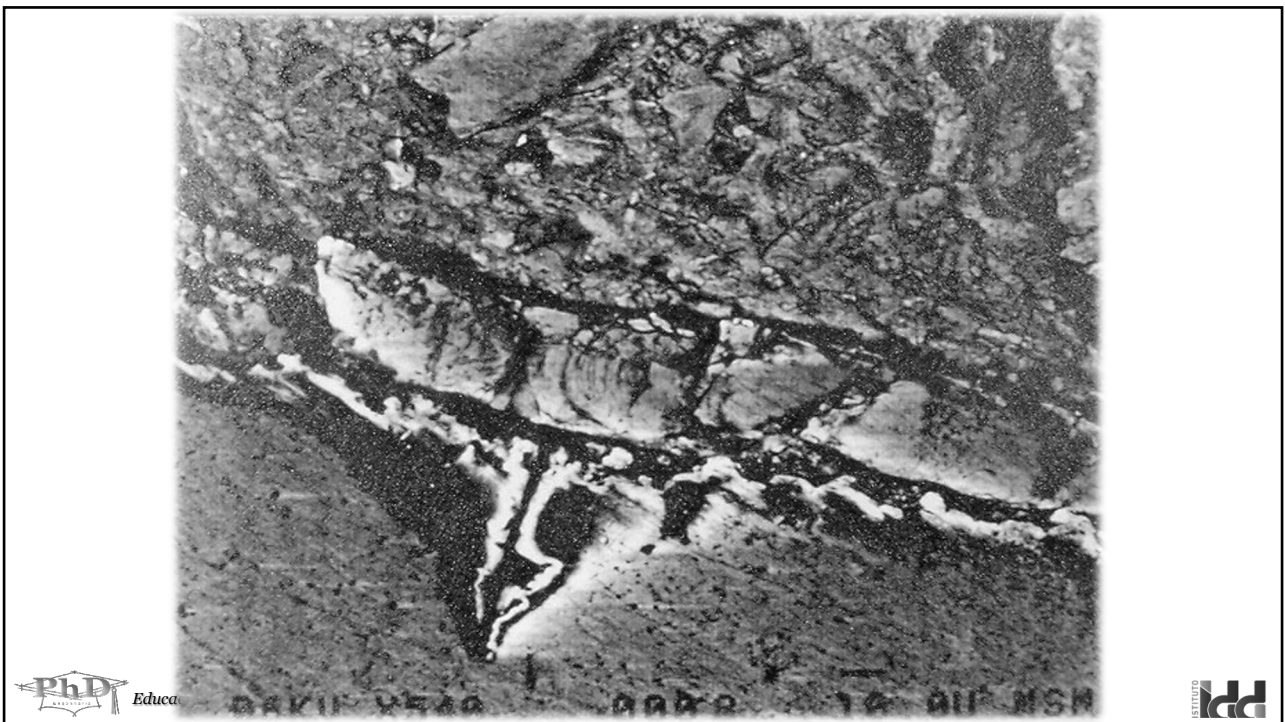

38

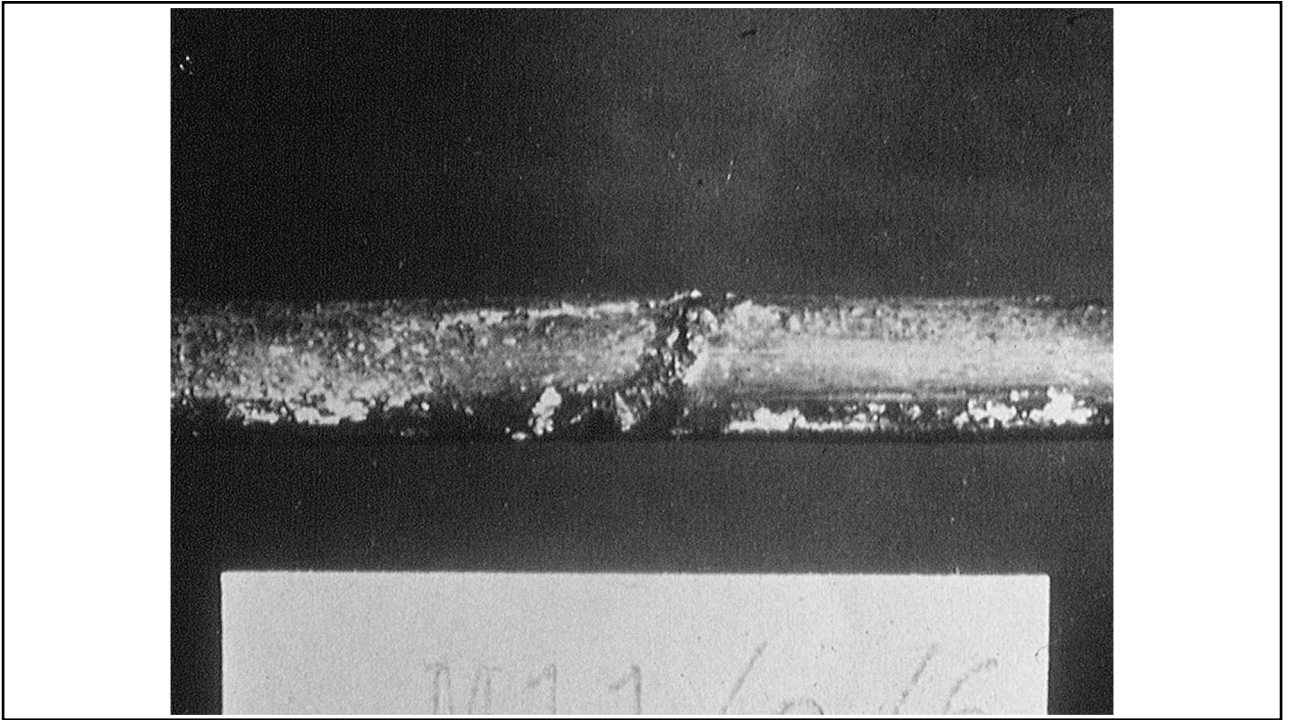

39



40



41



42

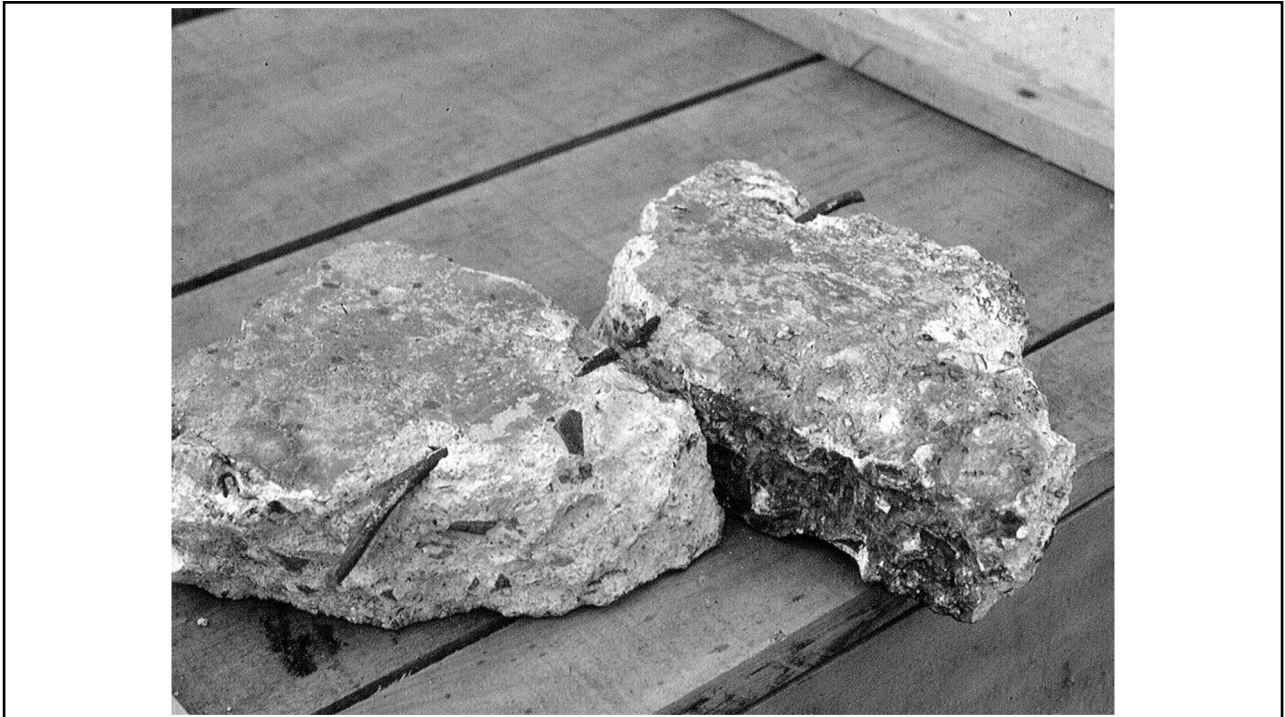

43

MENU G1 ESPÍRITO SANTO tvgozeta

19/07/2016 09h49 - Atualizado em 19/07/2016 19h32

Área de lazer em condomínio de luxo desaba e porteiro é achado morto

Drone mostra o estrago no Grand Parc, na Enseada do Suã, em Vitória. Suspeita é de vazamento de gás, segundo Corpo de Bombeiros.

Viviane Machado e Victoria Vrejão
Do G1 ES

FACEBOOK TWITTER G+ PINTEREST



As torres do condomínio de luxo Grand Parc Residencial Resort, na Enseada do Suã, em Vitória, foram esvaziadas após toda a **área de lazer desabar, na manhã desta terça-feira (19)**. Quatro pessoas ficaram feridas e **um porteiro ficou desaparecido até as 17h**. Ele foi encontrado **morto**. O desabamento aconteceu por volta de 3h.

Colapso

punzionamiento
área de recreación
de un condominio
de lujo

44



45



46

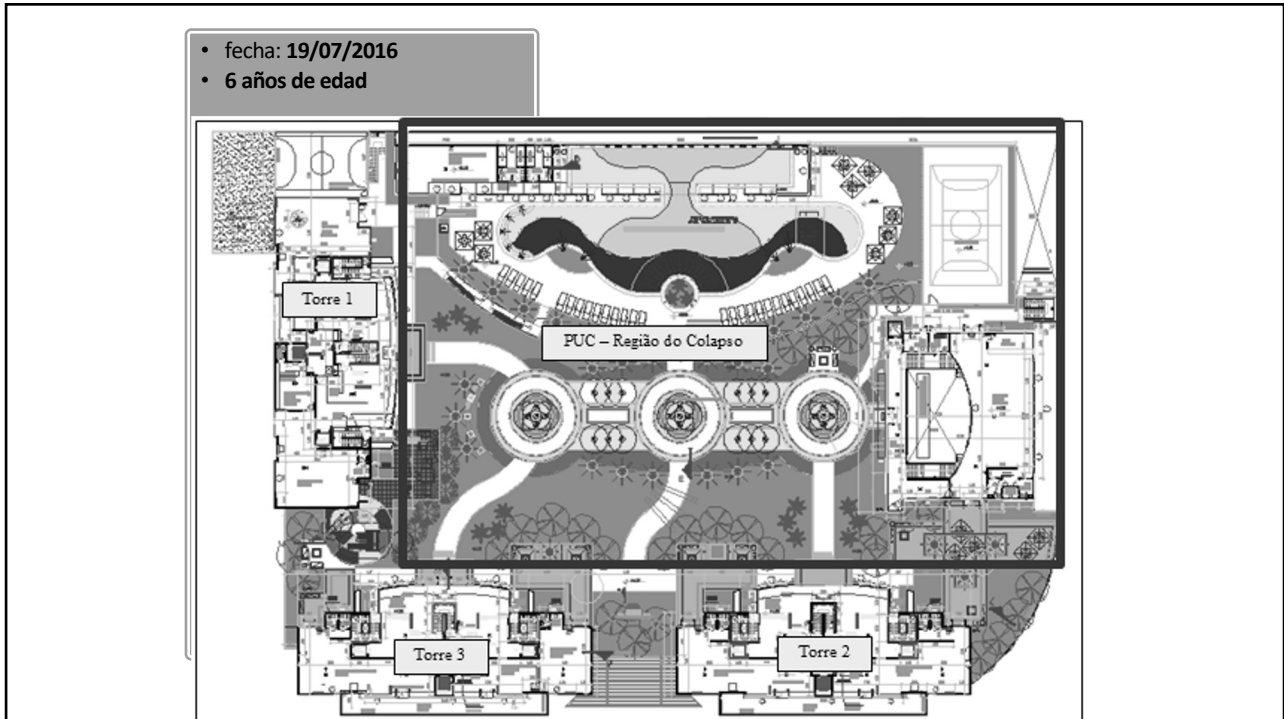

47

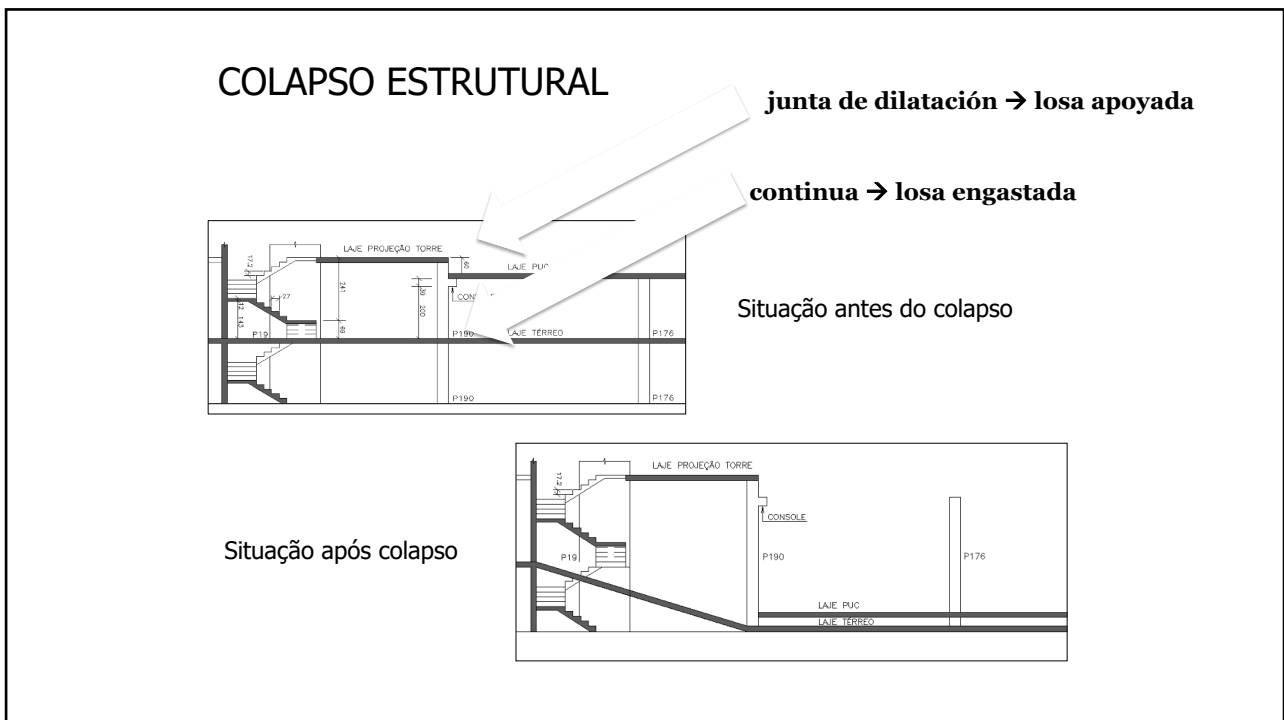

48



49



50



51



52



55



56

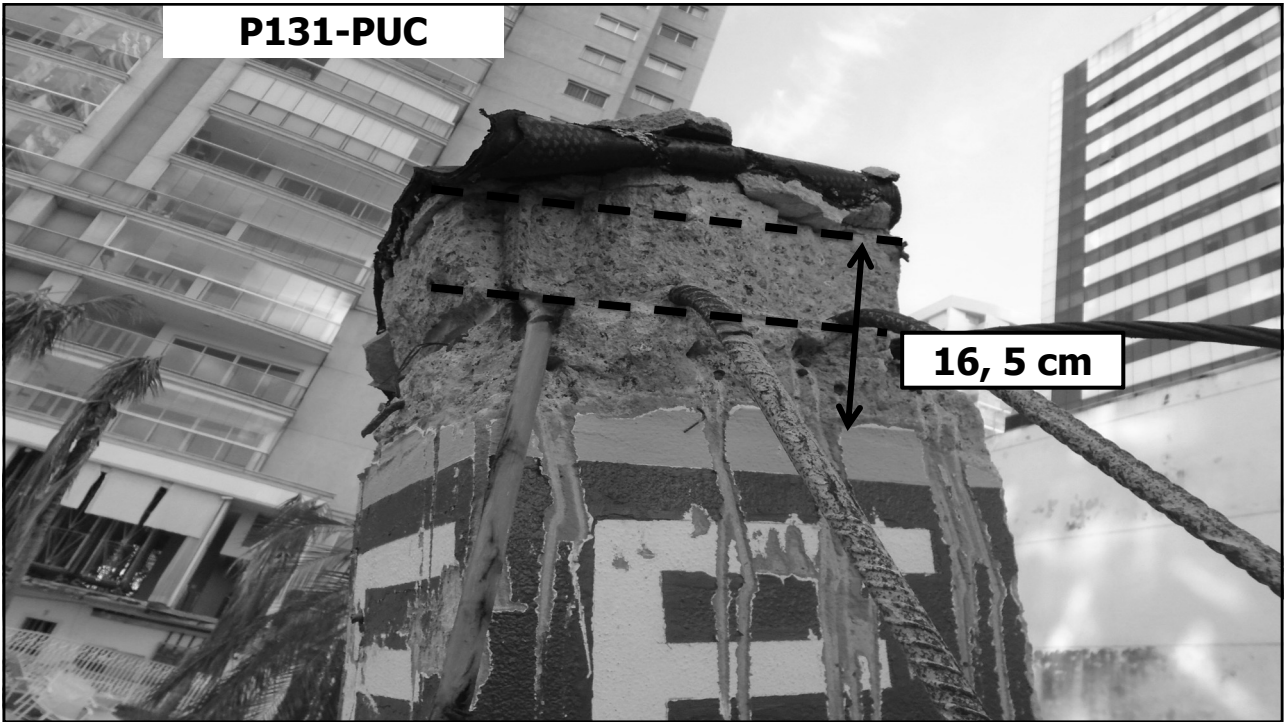

57



58



59



60



61



62

7/1/2021 40 Year Building Recertification Miami | Florida Inspections Unlimited

COVID-19 Update: We are open and following all CDC Guidelines to ensure your safety.



<https://www.homeinspectionsmiami.com/>



(305) 910-1171

Home
Services
Testimonials
Schedule an Inspection
Request A Quote
Pricing

Contact
Español

40 Year Building Recertification Miami

If you own old property in Miami chances are you've heard about 40 year building recertification. The ordinance was enforced in 1975 and then it was replaced in 2001 by the Florida Building Code. The recertification decree applies to buildings within counties in Florida with the exception of small structures, duplexes, and single family homes. Forms are issued by the county and normally sent to individuals along with notice for inspection.

How does it work?

40 year recertification requires that buildings in Florida be re-certified for electrical and structural safety every 40 years. Upon expiration of 40 years, the county or city building authority will send out a "Notice

REQUEST A QUOTE

63



October 8, 2018

Champlain Towers South
8777 Collins Avenue
Surfside, FL 33154

Attention: Ms. Maggie Manrara
Treasurer

**Re: Champlain Towers South Condominium
Structural Field Survey Report
MC Job# 18217**

Dear Ms. Manrara:

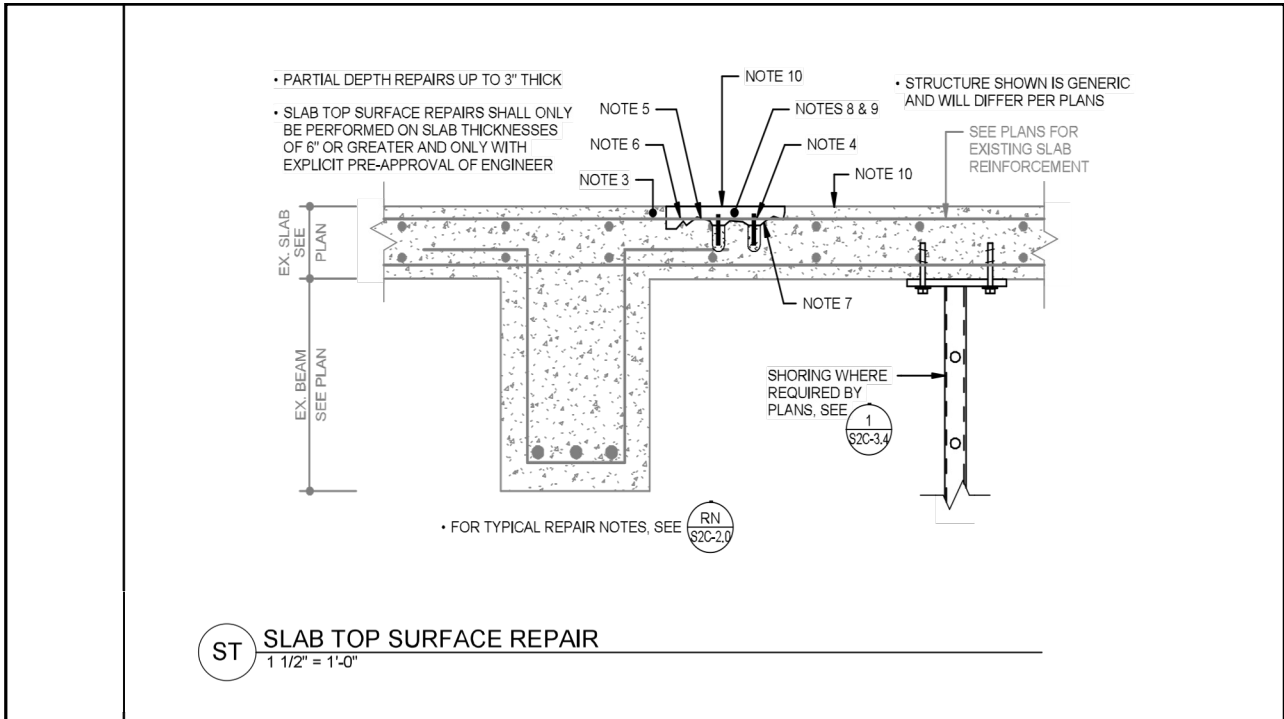

Morabito Consultants, Inc. (MC) is pleased to submit this structural engineering report of the Field Survey completed at the existing Champlain Towers South Condominium Complex (CTS) in Surfside, FL. The scope of this project includes a review of the existing 12 story plus penthouse 136-unit residential building, below-grade parking garage and at-grade exterior entrance drive, pool and recreation area. MC reviewed a representative sample of ~68 condominium units (half of the total units found in the building) along with the roof, exterior facade (observed from the balconies surveyed), parking garage,

64



67

- ❖ Pacometría - posición de los refuerzos
- ❖ Esclerometria - dureza superficial
- ❖ Ultrasonido - nidos de hormigonado
- ❖ Testigos - f_c concretos
- ❖ Espesor del recubrimiento
- ❖ Espesor de carbonatación
- ❖ Presencia o perfil de cloruros
- ❖ Diseño de grietas
- ❖ Identificación de áreas problemáticas

68

SurfSide MIAMI 2021 12 pisos

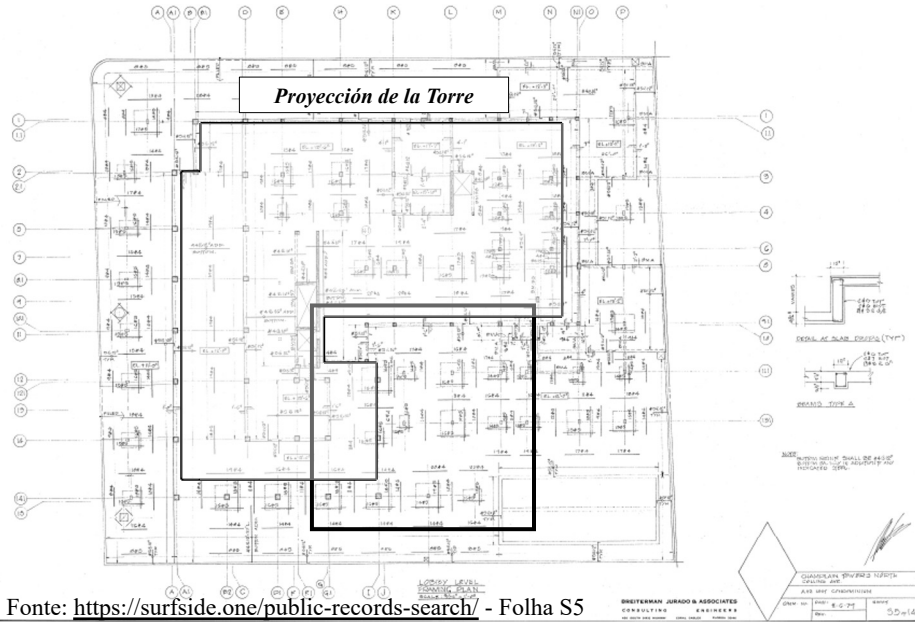

Fonte: <https://surfside.one/public-records-search/> - Folha S5

69

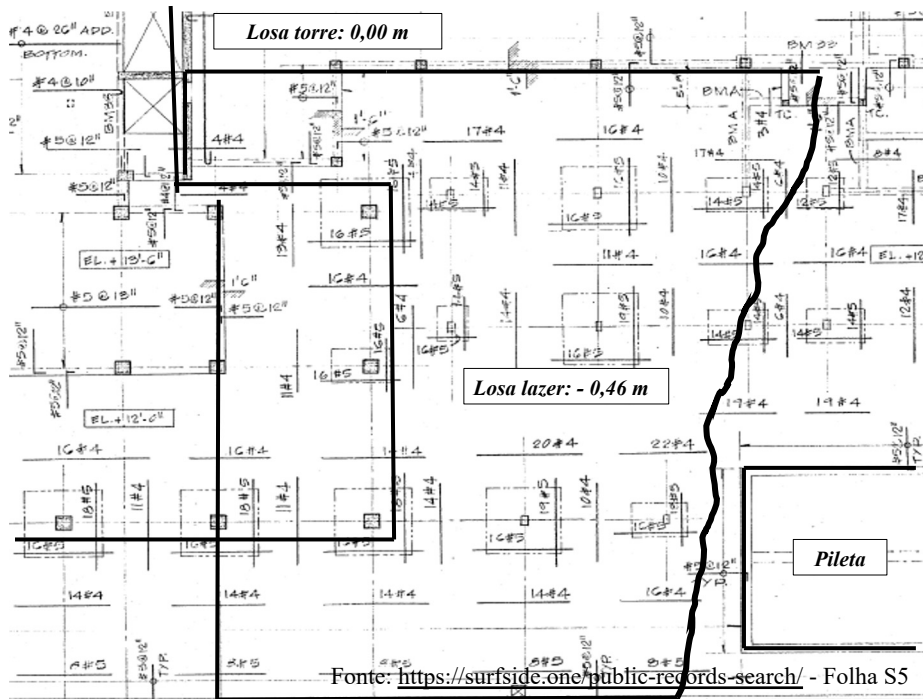

Fonte: <https://surfside.one/public-records-search/> - Folha S5

70

- ✓ Columnas de hormigón desde el garaje hasta el tercer piso:
6000psi (41.4 MPa)
 - ✓ Losas de hormigón de pisos: 4000psi (27.6 MPa)
- ✓ Refuerzo de la columna 61x61cm : 12Ø32 → $A_s=98.28\text{cm}^2$
→ $\rho=2.64\%$
- ✓ Refuerzo de la columna 41x41 cm : 8Ø36 → $A_s=80.48\text{cm}^2$
→ $\rho=4.79\%$
- ✓ Refuerzo de la columna 36x46 cm: 10Ø32→ $A_s=81.9\text{cm}^2$
→ $\rho=4.95\%$
- ✓ Losas de espesor: 25cm (planta baja), 20cm (tipo)
- ✓ Refuerzo de losas inferior: Ø12.7 C/30cm→ $\rho=0.17\%$ (planta baja), 0.19% (tipo)

Fonte: <https://surfside.one/public-records-search/> - Folhas S14 e S6

71

$f_{ck} = f'_c$ de las columnas en los pisos

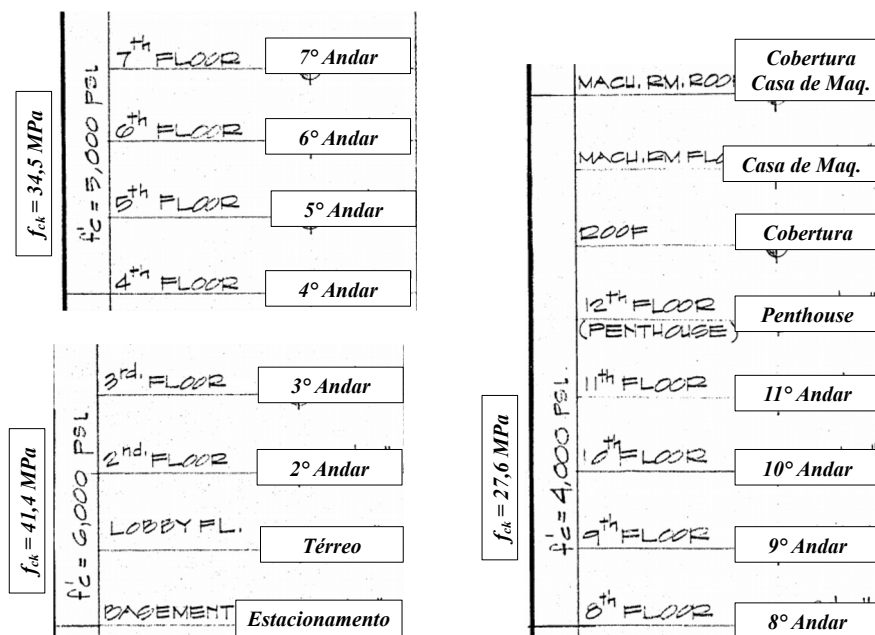

Fonte: <https://surfside.one/public-records-search/> - Folha S14

72

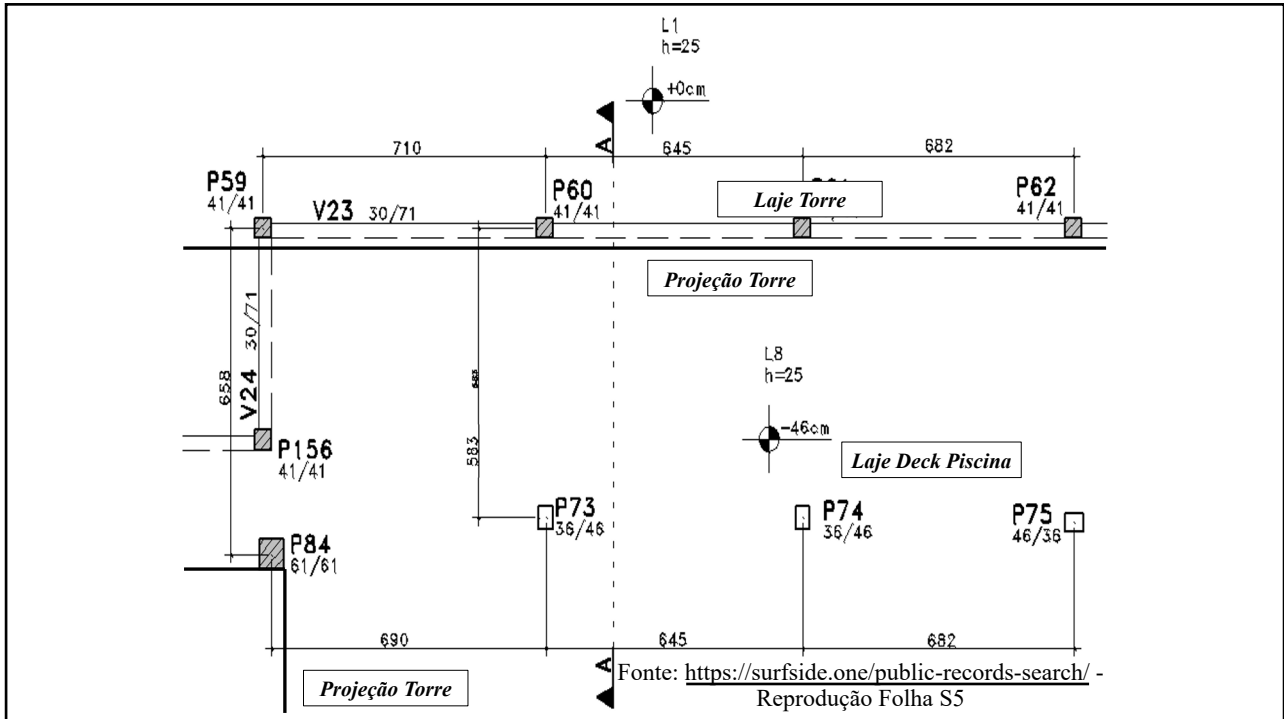

73

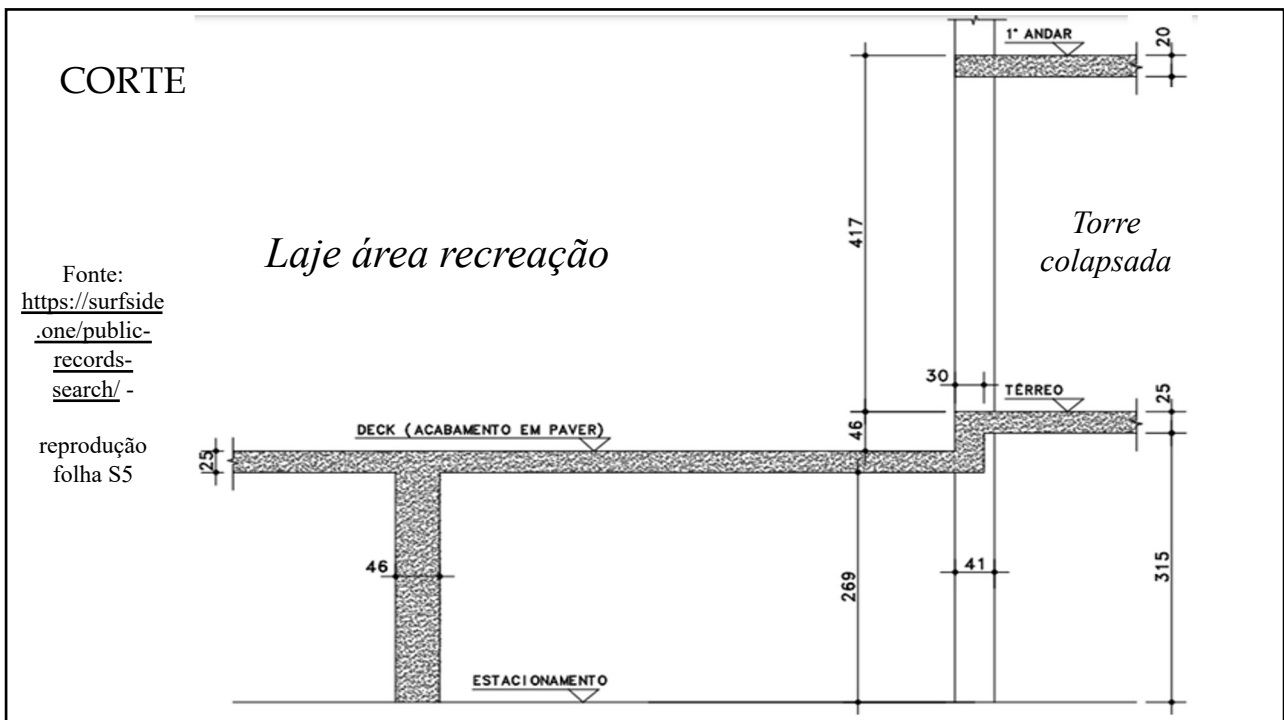

74

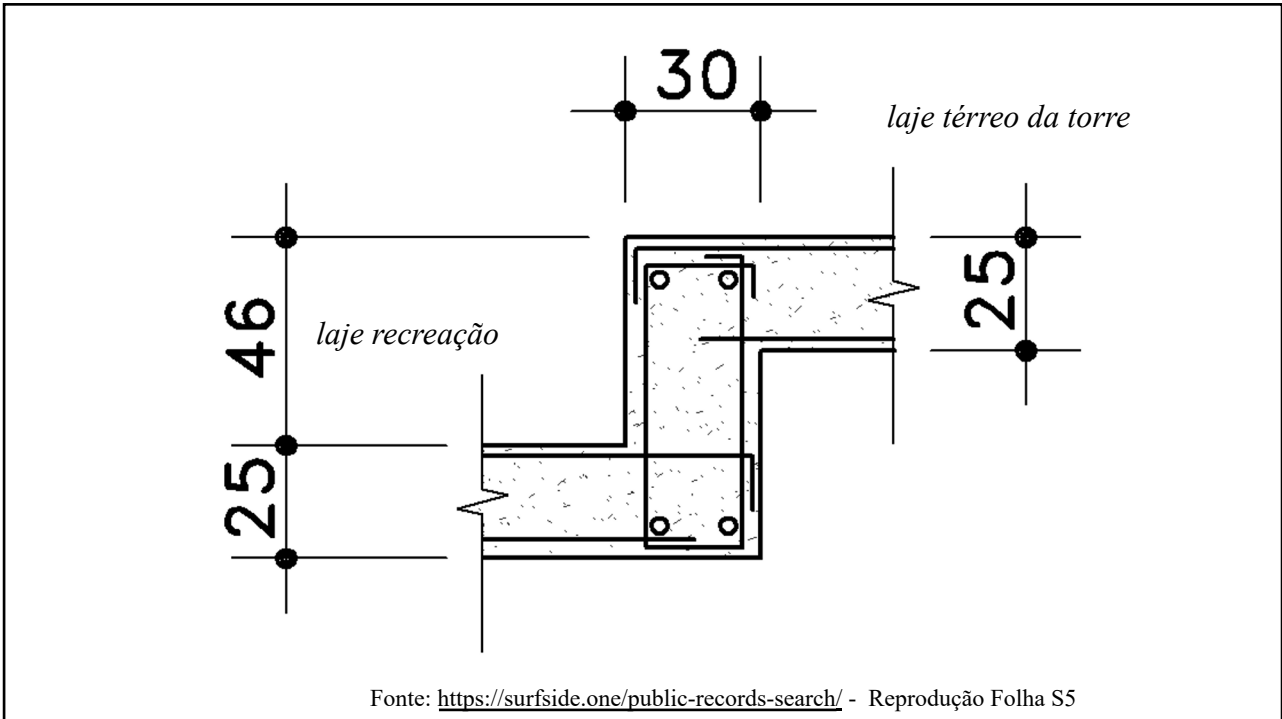

75

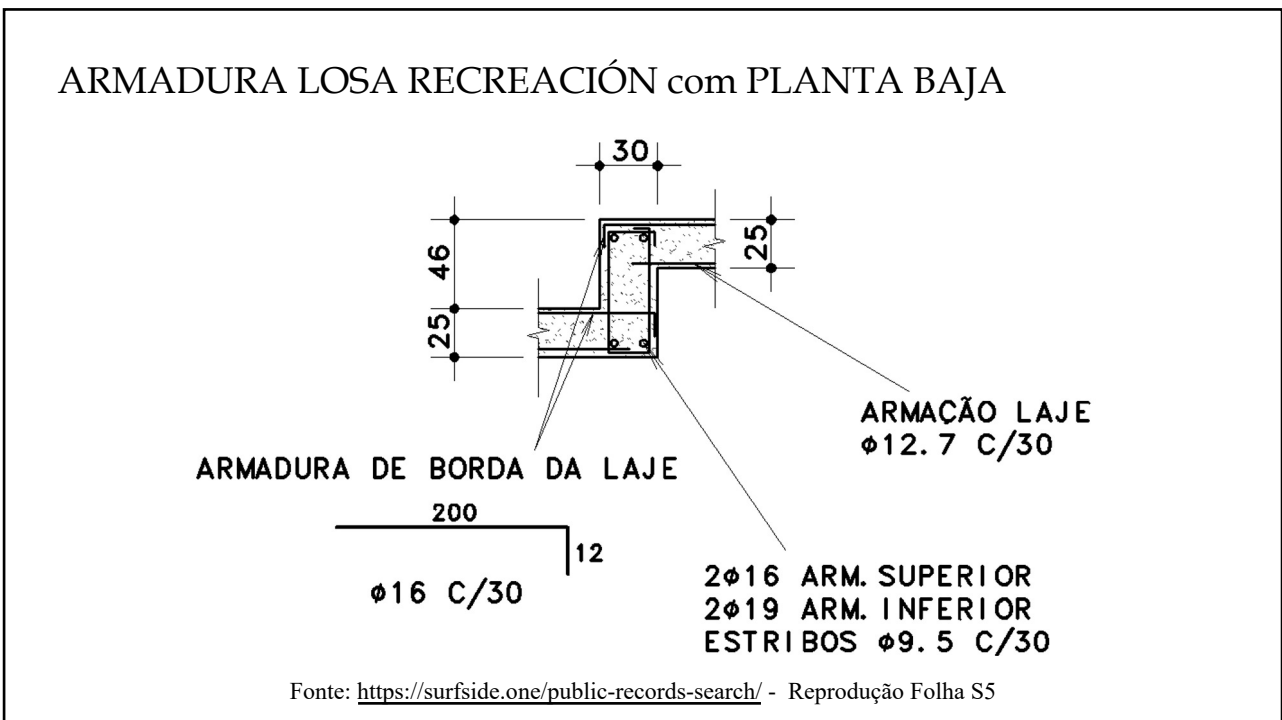

76

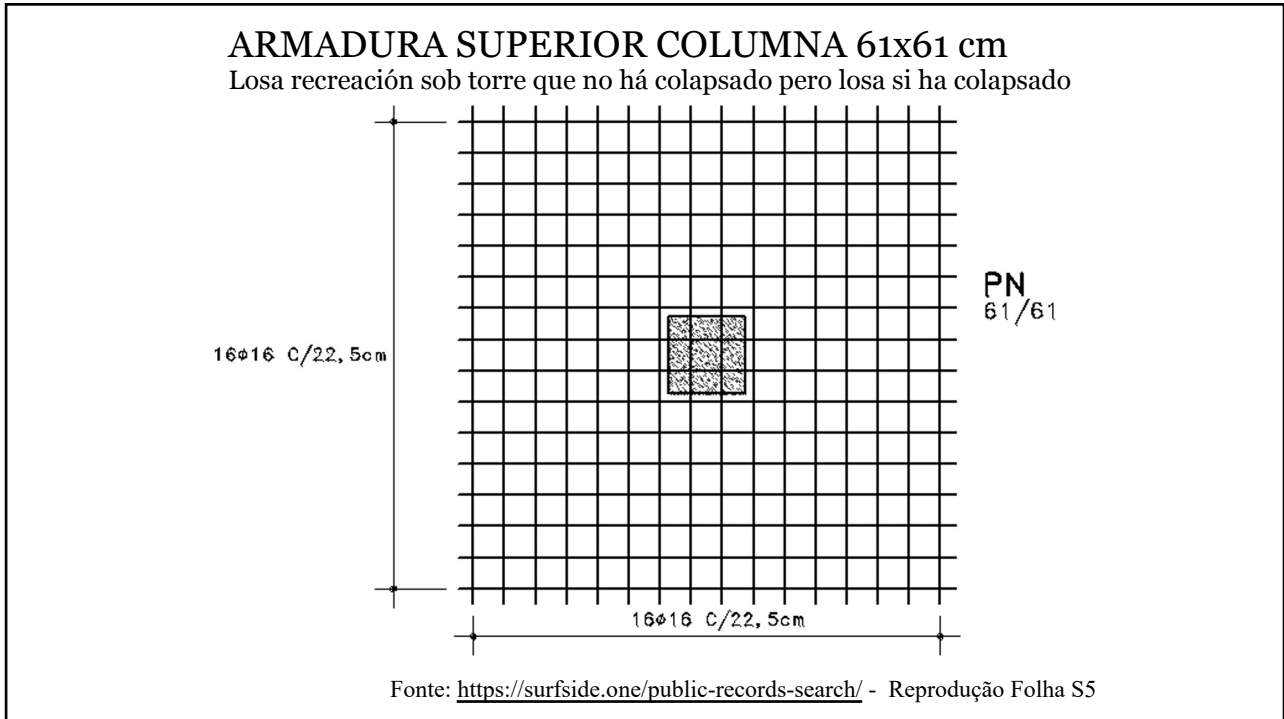

77

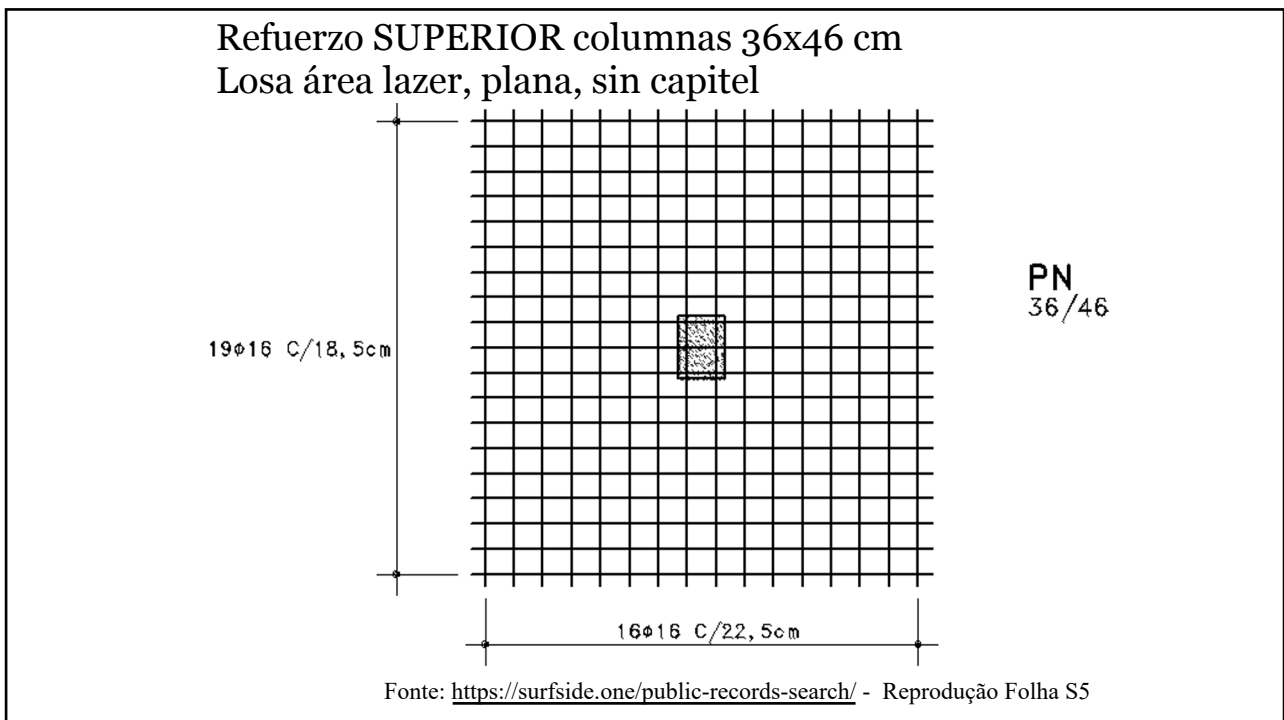

78



Fonte: Acervo PhD. Capitel com armadura de punção ("estribos")

79

CORTE TÍPICO NAS ARMAÇÕES DE PUNÇÃO E COLAPSO PROGRESSIVO (SEM CAPITEL)

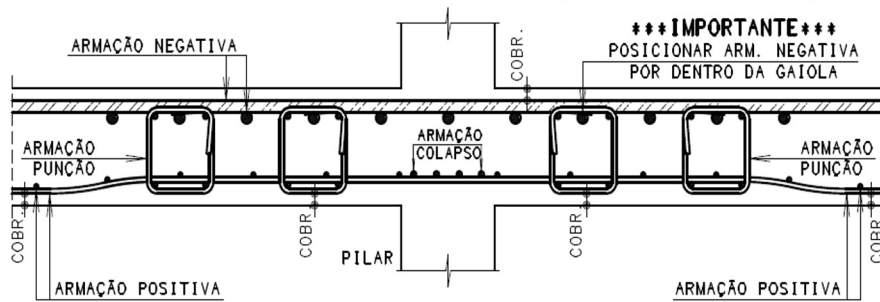

DETALHE DE AMARRAÇÃO NOS ESTRIBOS

AS BARRAS LONGITUDINAIS DEVEM ESTAR RIGOROSAMENTE ENCOSTADAS E AMARRADAS NOS QUATRO CANTOS DOS ESTRIBOS

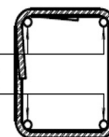

Fonte: Ricardo França & Associados

80



Figura 5.8
ETAPA 1 | Posicionamento dos conectores/studs

Fonte: Manual de Boas Práticas. Montagem das Armaduras de Estruturas de Concreto Armado. Jorge Nakashima (Sartoro) & Larissa Arakawa Martins. 2021

81

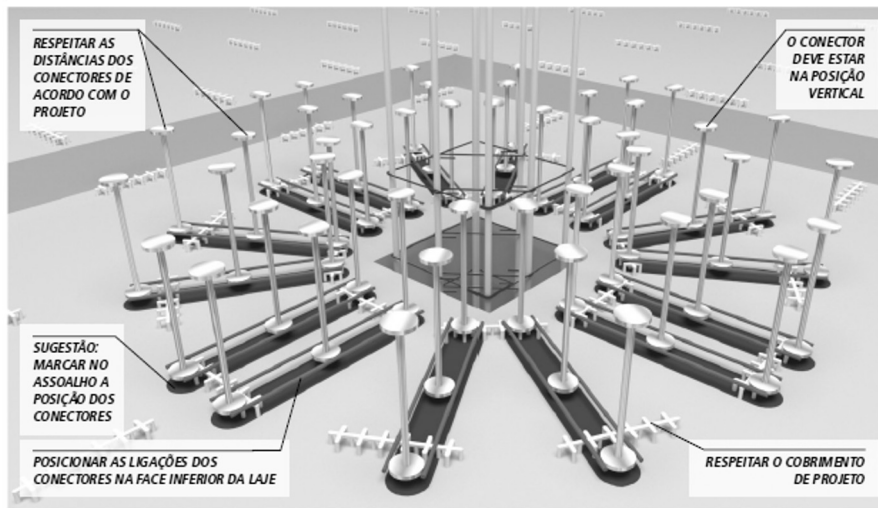
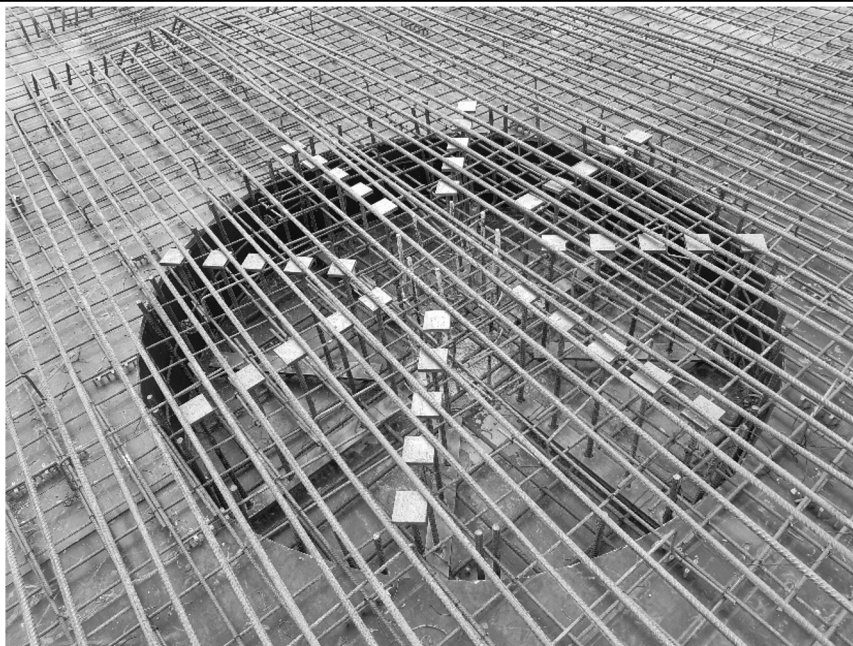

Fonte: Acervo PhD. Capitel com armadura de punção (“studs”).

82

Columnas colapsadas



Fonte: <https://www.nist.gov/disaster-failure-studies/champlain-towers-south-collapse/news-and-updates->

83

Columnas colapsadas



Fonte:
<https://www.nist.gov/disaster-failure-studies/champlain-towers-south-collapse/news-and-updates->

84

Column colapsada

Fonte:
[https://www.nist.gov/
disaster-failure-
studies/champlain-
towers-south-
collapse/news-and-
updates-](https://www.nist.gov/disaster-failure-studies/champlain-towers-south-collapse/news-and-updates-)



85

Losas



Fonte: [https://www.nist.gov/disaster-failure-studies/champlain-towers-south-
collapse/news-and-updates-](https://www.nist.gov/disaster-failure-studies/champlain-towers-south-collapse/news-and-updates-)

86

Fonte:
<https://www.nist.gov/disaster-failure-studies/champlain-towers-south-collapse/news-and-updates->



Losas
y
columnas

87



Losa
punzion

Fonte:
<https://www.nist.gov/disaster-failure-studies/champlain-towers-south-collapse/news-and-updates->

88

apartado 20.12

“Punzonamiento”

pág. 418 a 422

Hormigón Armado

14^o Edición

Basada en la EHE

Publicada em 2000

Pedro Jiménez Montoya

Álvaro García Meseguer

Francisco Morán Cabre



89

Losa Recreación Pileta → Punzonamiento

$e_{\text{nominal}} = 25 \text{ cm} \rightarrow \text{canto} \rightarrow d = 22 \text{ cm}$

Carga peso próprio = 625 kgf/m²

Carga Permanente= 450 kgf/m²

Total : 1300 kgf/m²

Carga Acidental= 225 kgf/m²

Columnas 36 cm x 46 cm a cada 6,5 m por 7,0 m

Superfície crítica → 2,5 m² → carga en la columna = 55000 kgf

$f_{ck} = 27,6 \text{ MPa (N/mm}^2\text{)}$

Cuantía = 0,01 coeficiente $\beta = 1,15$

Normal solicitante → $F_{sd} = 550 * \gamma_F$ (kN)

Perímetro crítico → $\mu_1 = 440 \text{ cm}$

Fonte: <https://surfside.one/public-records-search/> - Folhas S5, S6 e S14

90

Losa Recreación Pileta → Punzonamiento
corrosión del acero

$$\tau_{rd} = 0,12 * \left(1 + \sqrt{\frac{200}{d}}\right) * \sqrt[3]{(100 * \rho_l * f_{ck})}$$

$$\tau_{sd} = \frac{\beta * Fsd}{\mu_1 * d}$$

91

Losa Recreación Pileta → Punzonamiento
corrosión del acero

$$\tau_{sd} = \tau_{rd}$$

$$\tau_{rd} = 0,70 \text{ N/mm}^2 \text{ (MPa)}$$

$$\tau_{sd} = 0,65 * \gamma_F$$

(1,4 ?!)

$$\gamma_F = 1,08$$

(1,5 ?!)

92

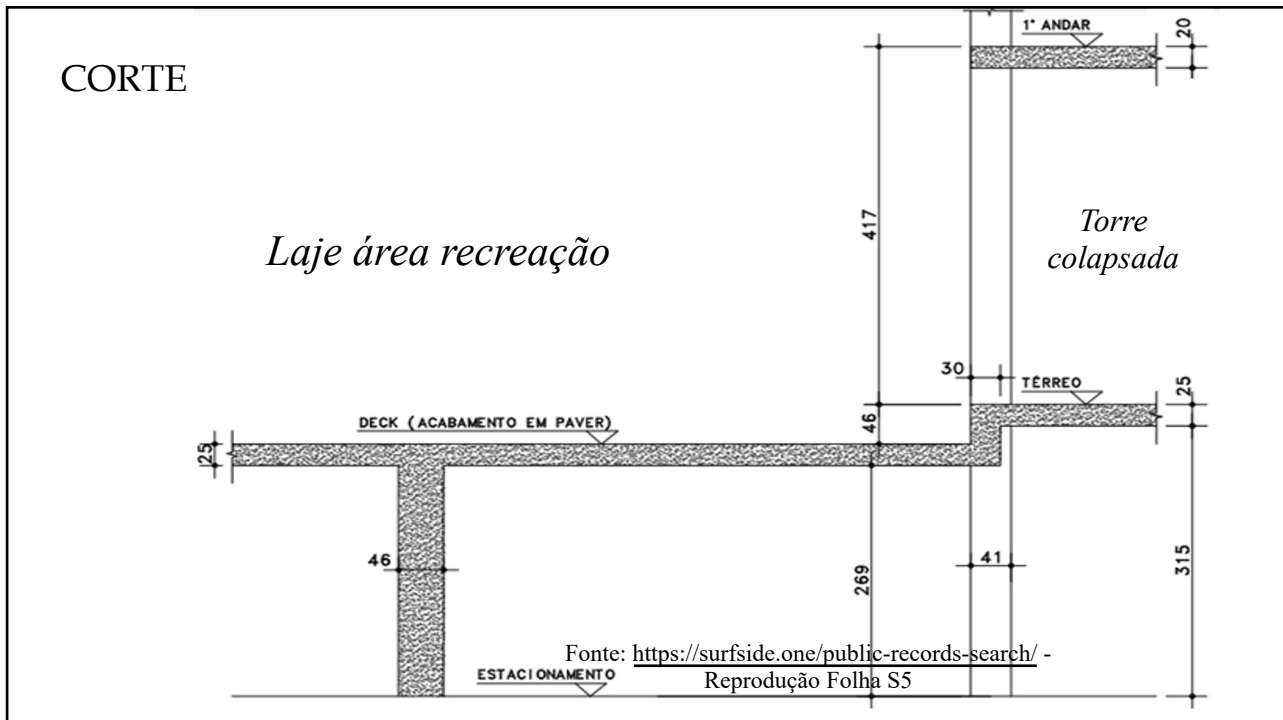

93

Losa Recreación Pileta → Punzonamiento

Superfície crítica → 2,5 m² → carga en la columna = 55000 kgf

Recalque 1mm → carga extra en la columna ≈ 2800 kgf

$$\tau_{rd} = 0,70 \text{ N/mm}^2 \text{ (MPa)}$$

$$\tau_{sd} = 0,68 * \gamma_F$$

$$\gamma_F = 1,03$$

94

Losa Recreación Pileta → Punzonamiento

Superficie crítica → 2,5 m² → carga en la columna = 55000 kgf

Recalque 2mm → carga extra en la columna ≈ 5300 kgf

$$\tau_{rd} = 0,70 \text{ N/mm}^2 \text{ (MPa)}$$

$$\tau_{sd} = 0,71 * \gamma_F$$

$$\gamma_F = \mathbf{0,99}$$

95

Lecciones

- ❖ Nuestras condolencias y solidaridad con las familias afectadas
- ❖ ATP (revisión del diseño estructural por pares)
- ❖ ATO (control tecnológico de estructuras por pares)
- ❖ ATU (inspección periódica y competente)
- ❖ Mantenimiento (obras)
- ❖ ¡Cuidado con el agua! Nunca menospreciar corrosión!
- ❖ Los edificios no son eternos y presentan problemas, años después
- ❖ Elegir profesionales bien preparados (certificación)
- ❖ El último ingeniero universal fue Leonardo da Vinci, multidisciplinar

96

