

Simpósio Mack Concreto

desempenho & durabilidade

Aprendendo com Acidentes: O Edifício de Miami e outros.



Prof. Paulo Helene

Diretor PhD Engenharia
Presidente do IBRACON
Prof. Titular Universidade de São Paulo
Ex-Presidente ALCONPAT Internacional
Conselheiro e sócio honorário do IBRACON
Deputy-chairman *fib* Model Code for Service Life Design
Conselheiro da SIURB, CNTU e SEESP



29/11/2021

1

National Institute of Standards and Technology (NIST)

- *NIST*, anteriormente conhecido por *National Bureau of Standards*, é uma agência governamental não reguladora do Departamento de Comércio dos Estados Unidos.
- *NCST National Construction Safety Team*, é um grupo do *NIST*, criado em 1 de outubro de 2002 pelo presidente George Bush para realizar inspeções e diagnósticos em edifícios colapsados, mas não tem a função de indicar um culpado, só diagnosticar.
- O colapso das *Champlain Towers South* é a quinta investigação do grupo *NCST*



NIST, 2021. Disponível em: <https://www.nist.gov/disaster-failure-studies/champlain-towers-south-collapse>. Acesso em: 07, Outubro, 2021.
Surface, 2021. Disponível em: <https://surfside.one/public-records-search/>. Acesso em: 07, Outubro, 2021.

2

World Trade Center *Terrorismo*

- Colapso 11/09/2001
- Relatório final Set. 2005 e Nov. 2008
- 2.996 mortos
- Lower Manhattan, Nova Iorque, Estados Unidos
- Diagnóstico: calor do incêndio sobre o aço



<https://www.nist.gov/el/final-reports-nist-world-trade-center-disaster-investigation>

3



Station Nightclub *Incêndio*

- Acidente 20/02/2003
- Relatório final: junho de 2005
- 100 mortos e mais de 187 feridos
- West Warwick, Rhode Island, EUA

<https://www.nist.gov/publications/report-technical-investigation-station-nightclub-fire-appendices-nist-ncstar-2-volume-2>

<https://www.nist.gov/publications/report-technical-investigation-station-nightclub-fire-nist-ncstar-2-volume-1>

4



5



6



7

Lições Aprendidas (*website:phd.eng.br*)

- 1. ATP, deve-se revisar o projeto estrutural frente a altas temperaturas ($\Delta = 250^{\circ} \text{C}$);**
- 2. Arquivar projeto executivo estrutural ou projeto "as built" em nuvens públicas (prefeituras);**
- 3. Inspeção periódica; Proteção passiva e ativa obrigatória; Redundância e robustez no projeto estrutural**

chrome-extension://efaidnbmnnnibpcajpcglclefindmkaj/viewer.html?pdfurl=http%3A%2F%2Fwww.phd.eng.br%2Fwp-content%2Fuploads%2F2019%2F04%2F19.04.30ParecerCompletoPaesAlmeida_final-compactado.pdf&clen=13968403&chunk=true

8



9

NIST encourages members of the public to submit any information, including video, photos or other documentation

- ✓ June 24, 2021, Champlain Towers South, 12-floor condominium in Surferside, Florida, at 1:30 a.m.
- ✓ June 25, NIST began a team of six scientists and engineers to collect firsthand information on the collapse.
- ✓ June 30 decided full technical investigation of the collapse by National Construction Safety Team (NCST) Act
- ✓ NCST's work will not interfere with the ongoing search-and-rescue operation at the scene of the collapse.
- ✓ NCST's role is not to determine any culpability.
- ✓ NCST investigation is to determine the technical diagnose and cause of the collapse and, learning from that, to recommend changes to building codes, standards and practices, and appropriate actions to improve the structural safety of buildings.
- ✓ NCST investigations are thorough and typically take years to complete.
- ✓ NCST team will provide updates on its progress, at its regular meetings, which are open to the public.

10

Robert Stephenson em seu discurso inaugural de posse à Presidência do Instituto de Engenheiros Civis da Grã-Bretanha, em 1856:

"Estou esperançoso de que todos os acidentes e problemas ocorridos nos últimos anos sejam registrados e revelados.

Nada é tão instrutivo para jovens engenheiros quanto o estudo de acidentes e sua correção.

Diagnosticar esses acidentes, entender os mecanismos de ocorrência, é mais valioso do que descrever trabalhos bem-sucedidos.

Engenheiros experientes também aprendem com esses ensinamentos e lições de acidentes que podem até ocorrer em seus próprios trabalhos.

Com esse nobre objetivo educacional, propomos catalogar esses problemas nos arquivos desta renomada instituição."

11

Inspeções do NCST/NIST Torres Champlain Sur

- Análise de solo e rocha
- Análise água subterrânea
- Uso raios laser (Lidar) para mapear a localização
- Drones para coletar imagens e registros
- Velocidade de pulso ultrassônico (VPU) para analisar o concreto da estrutura
- Acelerômetros para medir a vibração das Torres Champlain Norte (referência)

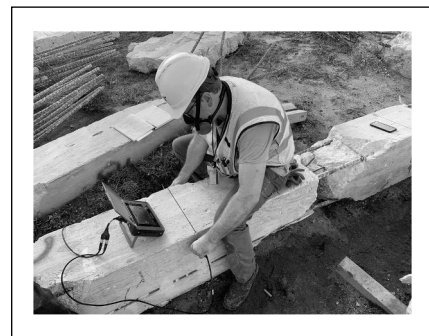

12



Inspeções

- Foram recolhidos cerca de 200 elementos construtivos
- As recomendações finais estarão disponíveis 90 dias após o término das investigações.

13



National Construction Safety Team (NCST)

Equipe Nacional de Segurança na Construção

Equipe Multidisciplinar

13 membros (PhD)

14

Judith Mitrani-Reiser

- Lidera pesquisas em Champlain Towers South (fluyente em inglês e espanhol)
- Chefe da Divisão de Materiais e Sistemas Estruturais do Laboratório de Engenharia NIST
- Universidade Civil de Engenharia da Flórida
- Mestrado na Universidade da Califórnia em Berkeley
- Doutorado mecânica aplicada do Instituto de Tecnologia da Califórnia







15

Glenn Bell





- 45 anos de experiência em projetos de reabilitação e pesquisa de falhas
- Investigou vários colapsos:
- Passarela do Hyatt Regency Hotel em Kansas City em 1981
- Torres 1 e 2 do World Trade Center
- Avaliou os efeitos das reações químicas alcali-sílica no concreto na Usina Nuclear da Estação Seabrook
- Engenheiro Civil na Universidade Tufts
- MSc & PhD engenharia estrutural e mecânica estrutural da Universidade da Califórnia, Berkeley



16

	David Goodwin → químico, PhD	
	Jim Harris → Normas históricas vigentes na época do projeto estrutural e da construção, PhD	
	Youssef Hashash → geotécnia, PhD	
	Ken Hover → ciência dos materiais, PhD	

17

	Scott Jones → ciência dos materiais, PhD	
	Jack Moehle → engenheiro estrutural, PhD	
	Sissy Nikolaou → geotecnia, PhD	
	Long Phan → construtor e estruturas, PhD	
	Fahim Sadek → inspeção estrutural, PhD	
	Chris Segura → estruturas, PhD	
	Jonathan Weigand → estruturas, PhD	

18



19

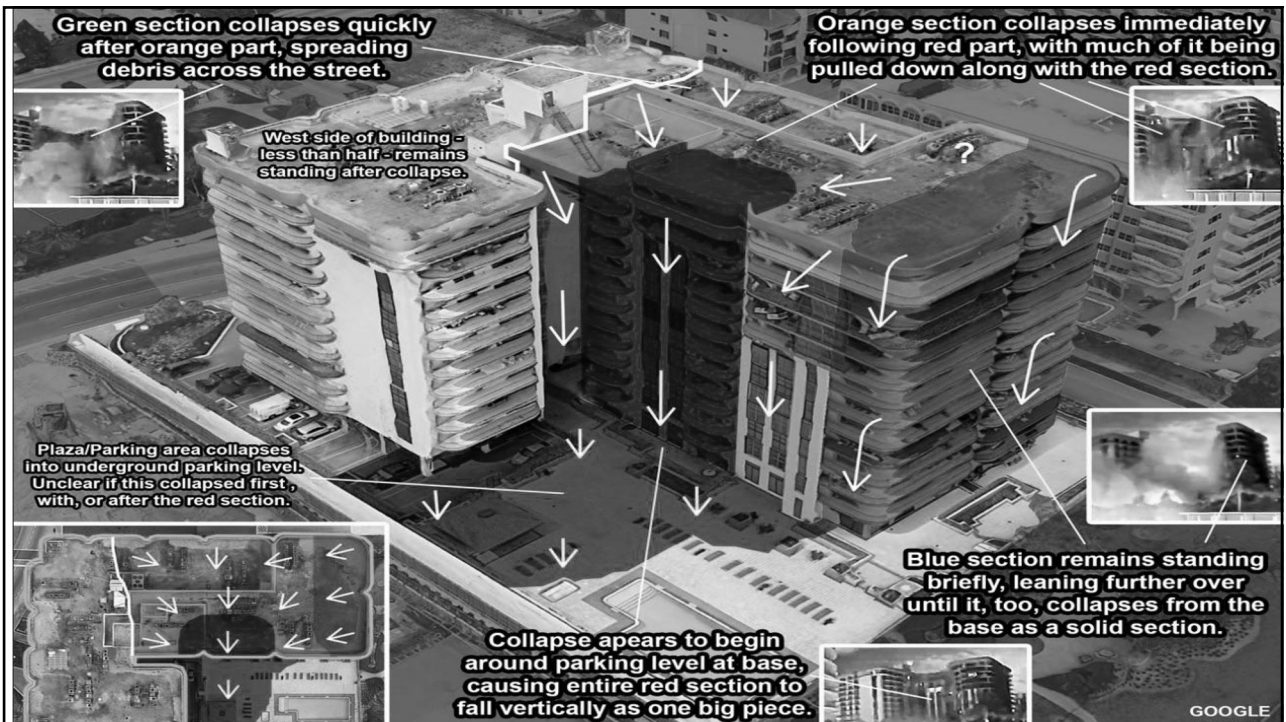

20



21

Há consenso

Começou com a ruptura por punção da laje da área de recreação

Perguntas, Dúvidas ?

- 1. Qual foi o gatilho, depois de 40 anos?*
- 2. Como se propagou para as torres ?*

22

Hipótese 1:

Corrosão de armadura ocorrida nas fissuras de punção na face superior da laje da área de recreação junto à cabeça dos pilares que a sustentam, devido a uma eventual carga acima da considerada no projeto ocorrida ao longo dos 40 anos ou um projeto muito no limite

23

Hipótese 2:

Recalque diferencial entre torre e a laje de recreação que induziu aumento substancial de carga de punção nas lajes sobre a cabeça dos pilares de secção 36cm por 46cm

**Mais provável:
hipótese 1 + hipótese 2**

24



25

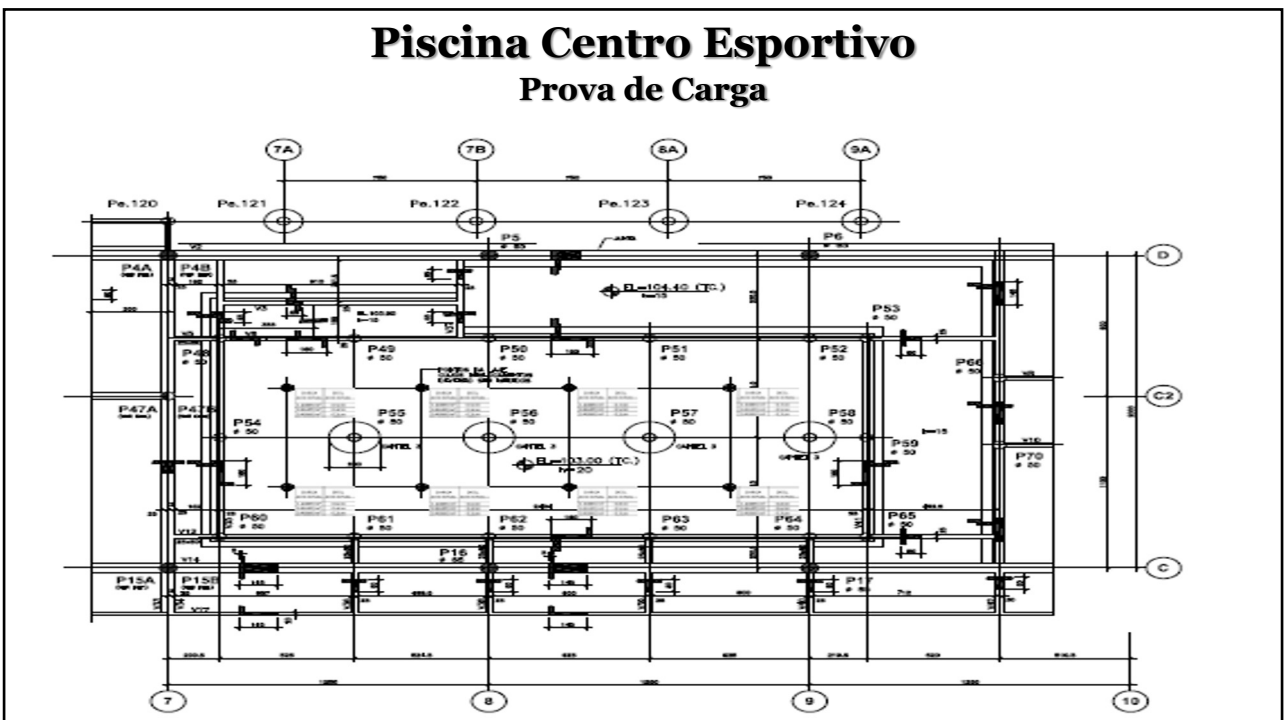

26



27



28



29



30

Paulo Helene

MANUAL

PARA REPARO, REFORÇO E PROTEÇÃO DE ESTRUTURAS DE CONCRETO

Projeto de Divulgação Tecnológica



Punção

Manifestação Típica



31

Fissuração: Carbonatação e Cloreto

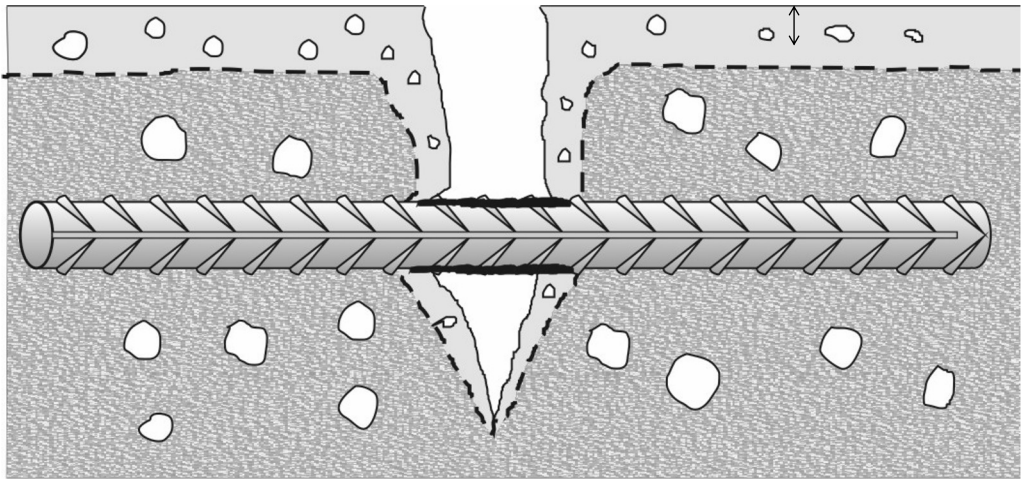

espessura carbonatada

w_k peças a flexão $\gamma_F = 1$

32

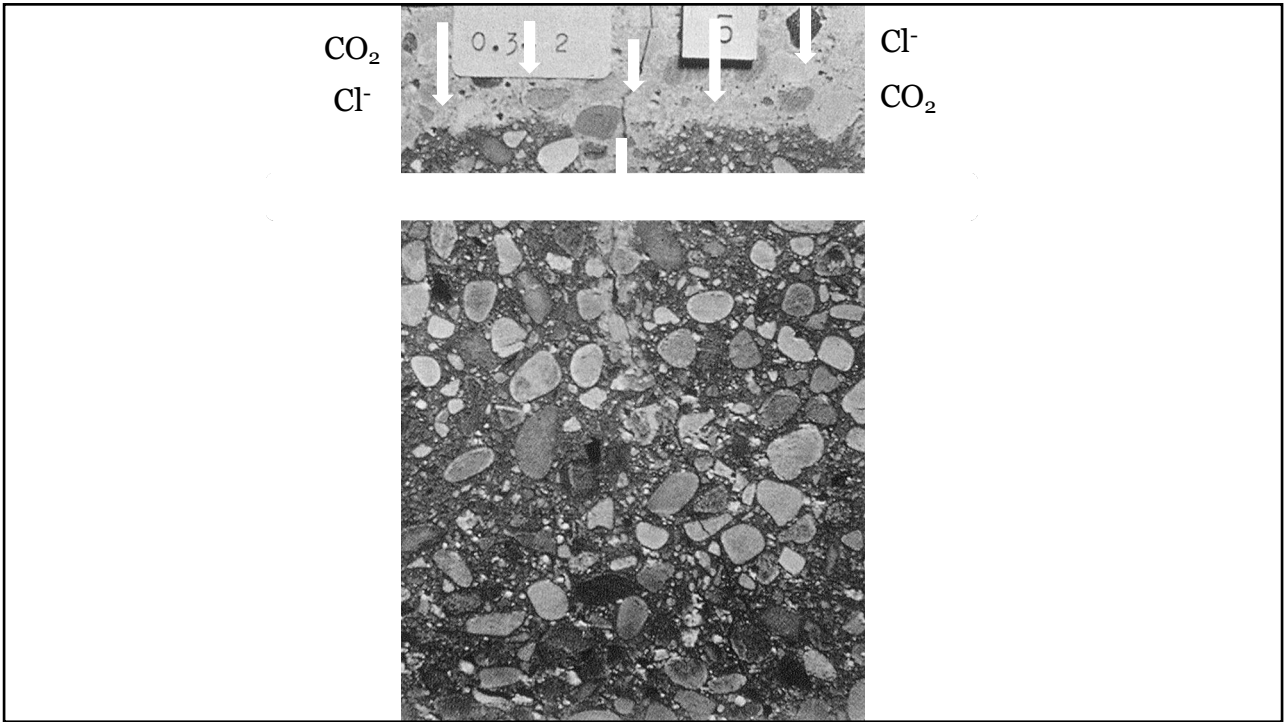

33

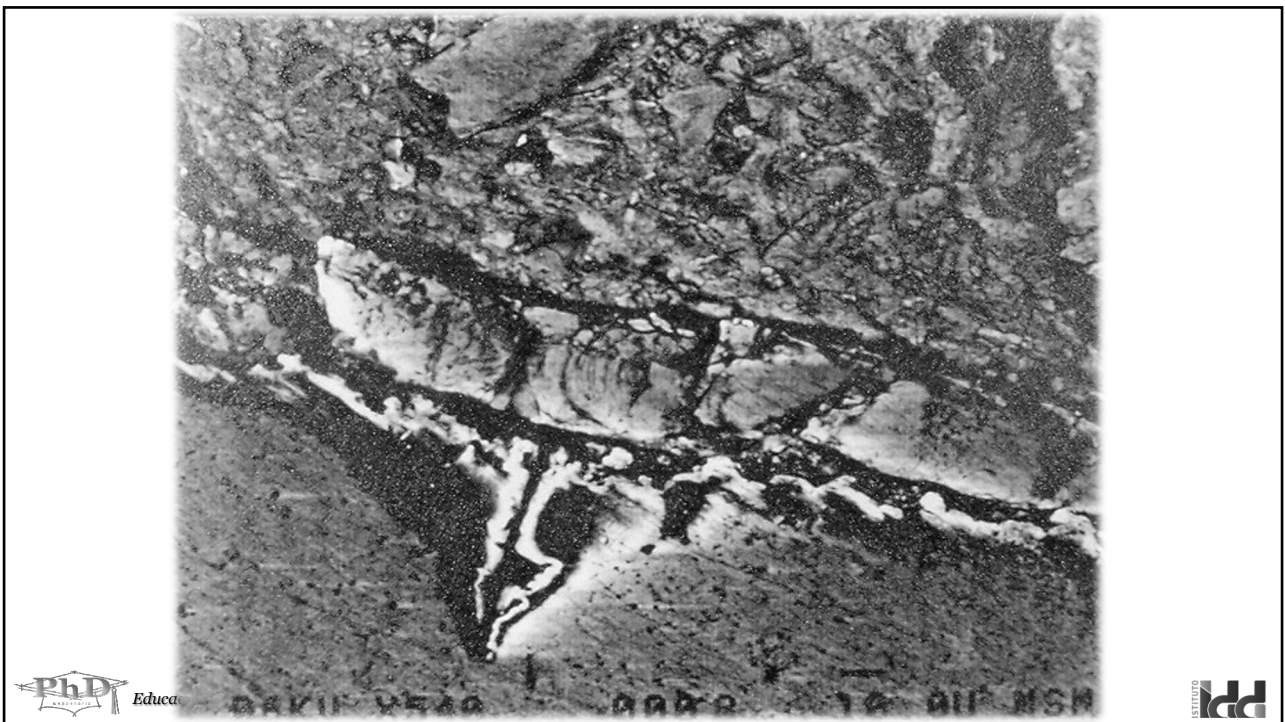

34

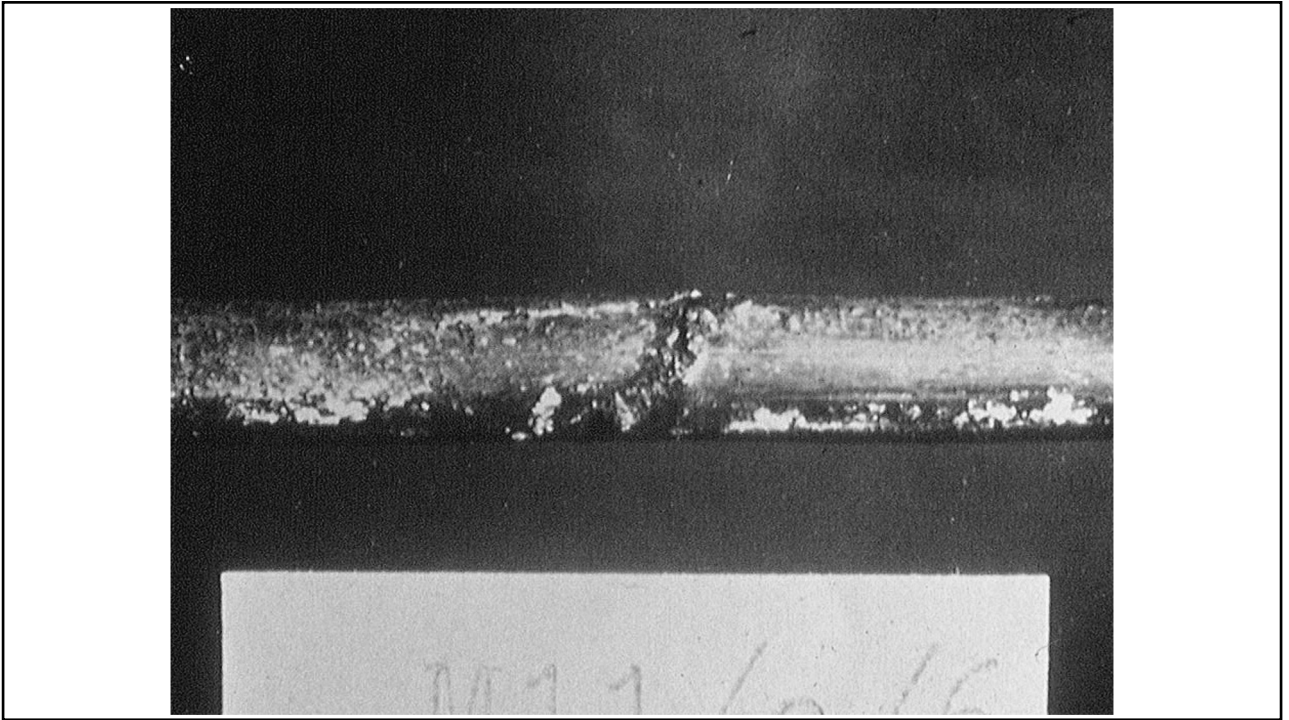

35



36



37



38

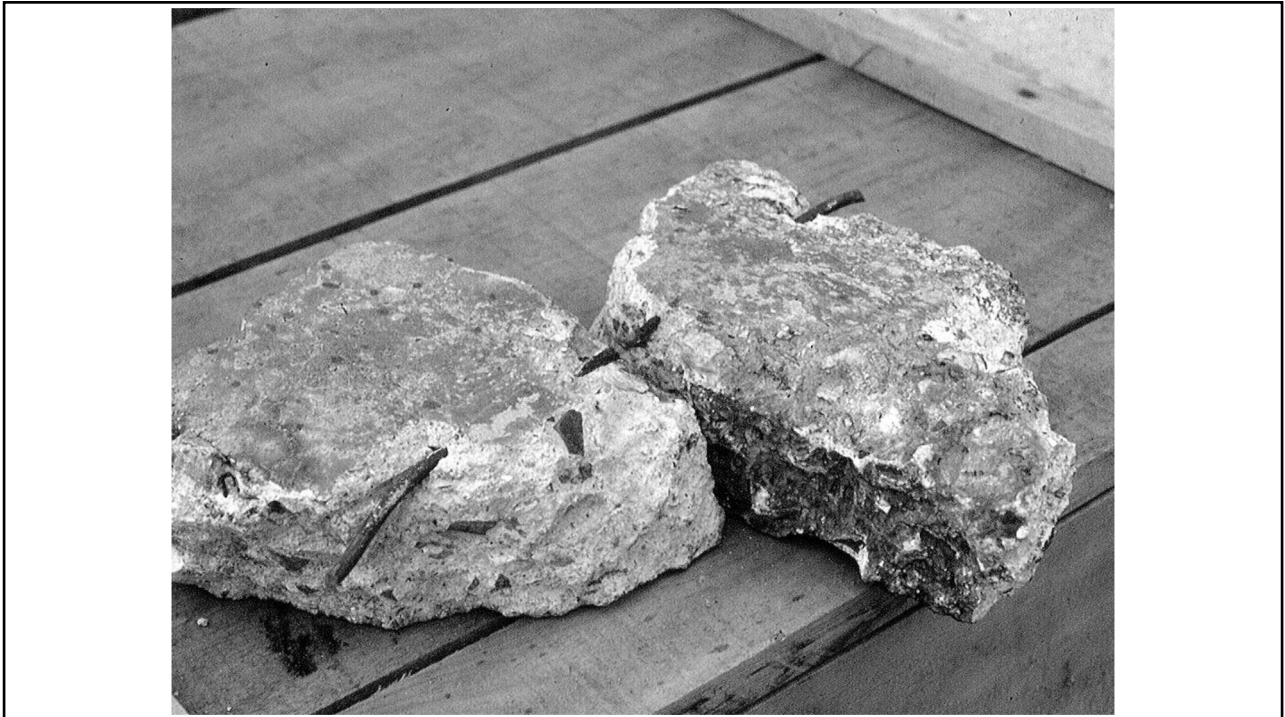

39

MENU G1 ESPÍRITO SANTO 

19/07/2016 09h49 - Atualizado em 19/07/2016 19h32

Área de lazer em condomínio de luxo desaba e porteiro é achado morto

Drone mostra o estrago no Grand Parc, na Enseada do Suã, em Vitória. Suspeita é de vazamento de gás, segundo Corpo de Bombeiros.

Viviane Machado e Victoria Vrejão
Do G1 ES

 FACEBOOK   



As torres do condomínio de luxo Grand Parc Residencial Resort, na Enseada do Suã, em Vitória, foram esvaziadas após toda a **área de lazer desabar, na manhã desta terça-feira (19)**. Quatro pessoas ficaram feridas e **um porteiro ficou desaparecido até as 17h**. Ele foi encontrado **morto**. O desabamento aconteceu por volta de 3h.

Colapso

punção
área de recreação
de un condominio
de luxo

40



41



42

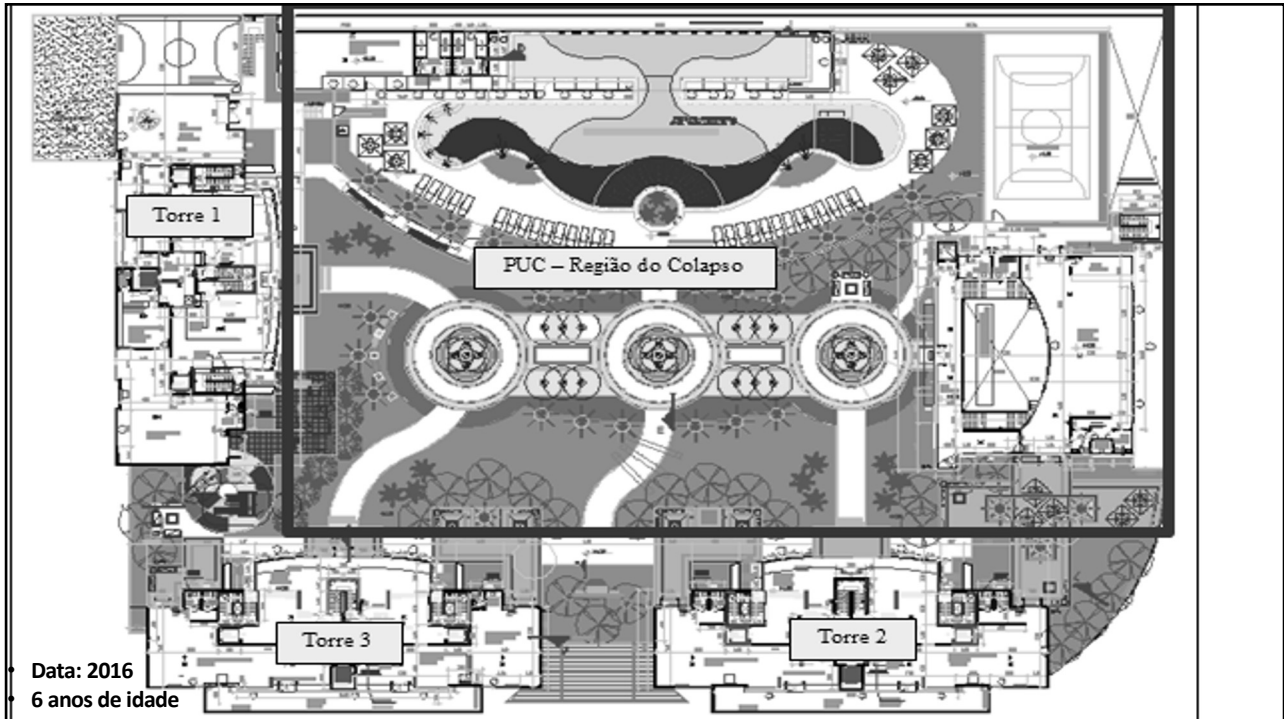

43

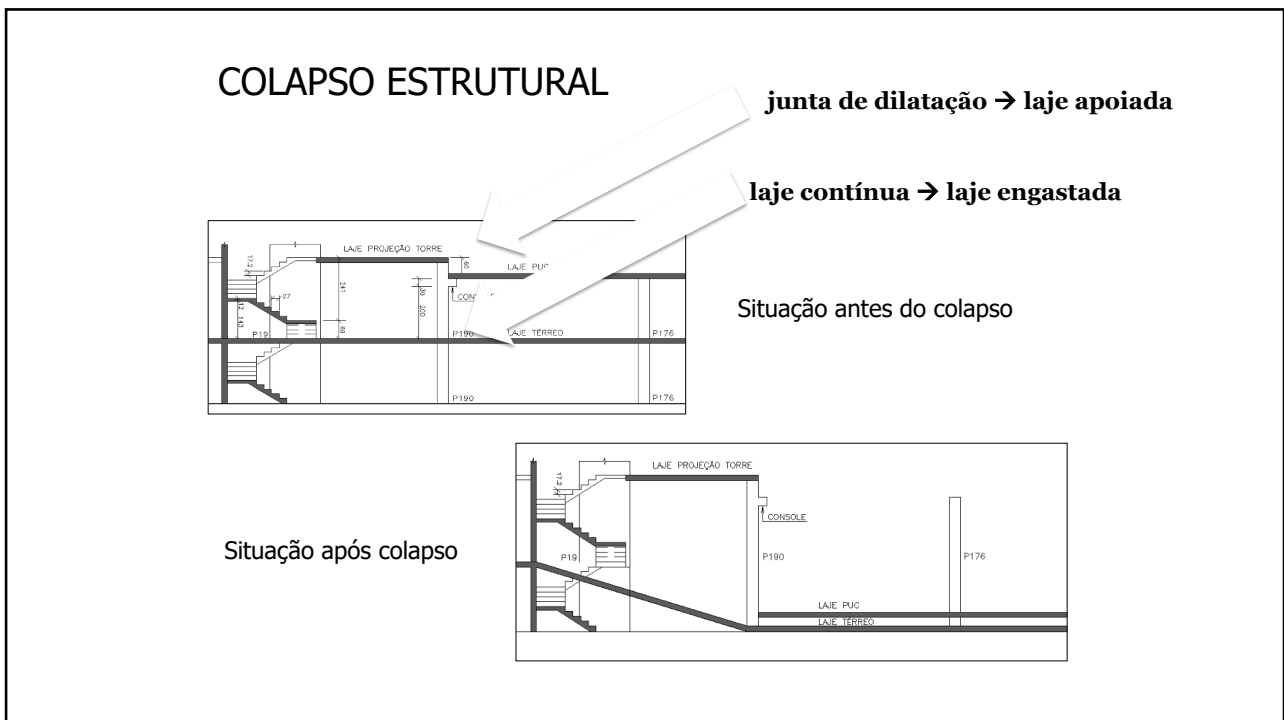

44



45



46



47



48

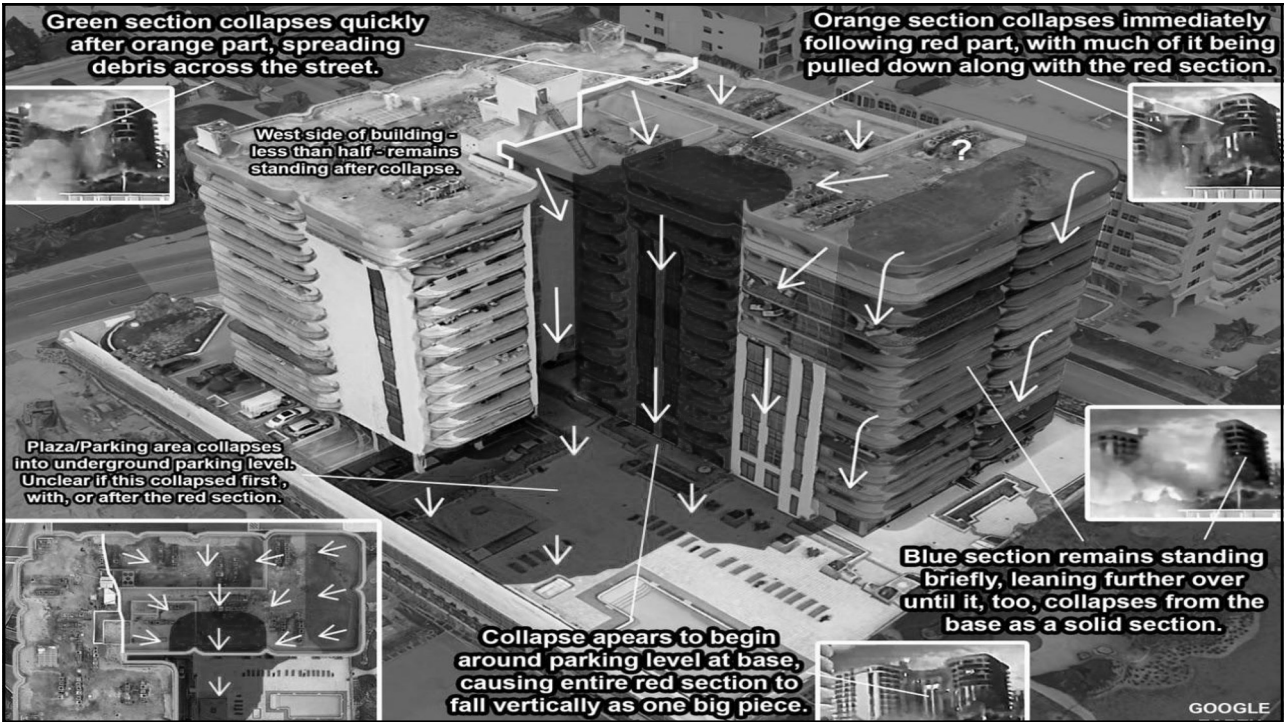

49



50



51



52

7/1/2021 40 Year Building Recertification Miami | Florida Inspections Unlimited

COVID-19 Update: We are open and following all CDC Guidelines to ensure your safety.



<https://www.homeinspectionsmiami.com/>



(305) 910-1171

Home
Services
Testimonials
Schedule an Inspection
Request A Quote
Pricing

Contact
Español

40 Year Building Recertification Miami

If you own old property in Miami chances are you've heard about 40 year building recertification. The ordinance was enforced in 1975 and then it was replaced in 2001 by the Florida Building Code. The recertification decree applies to buildings within counties in Florida with the exception of small structures, duplexes, and single family homes. Forms are issued by the county and normally sent to individuals along with notice for inspection.

How does it work?

40 year recertification requires that buildings in Florida be re-certified for electrical and structural safety every 40 years. Upon expiration of 40 years, the county or city building authority will send out a "Notice

REQUEST A QUOTE

53



October 8, 2018

Champlain Towers South
8777 Collins Avenue
Surfside, FL 33154

Attention: Ms. Maggie Manrara
Treasurer

**Re: Champlain Towers South Condominium
Structural Field Survey Report
MC Job# 18217**

Dear Ms. Manrara:

Morabito Consultants, Inc. (MC) is pleased to submit this structural engineering report of the Field Survey completed at the existing Champlain Towers South Condominium Complex (CTS) in Surfside, FL. The scope of this project includes a review of the existing 12 story plus penthouse 136-unit residential building, below-grade parking garage and at-grade exterior entrance drive, pool and recreation area. MC reviewed a representative sample of ~68 condominium units (half of the total units found in the building) along with the roof, exterior facade (observed from the balconies surveyed), parking garage,

54

O RELATÓRIO DA INSPEÇÃO DA FIRMA "MORABITO CONSULTANTS" DE 2018

DÁ ALGUMAS CLARAS INFORMAÇÕES SOBRE ESSE ITEM

VER NO LINK

https://www.townofsurfsidefl.gov/docs/default-source/default-document-library/town-clerk-documents/champlain-towers-south-public-record-8777-collins-ave---structural-field-survey-report.pdf?sfvrsn=882a1194_2

" The Pool Deck and Entrance Drive areas were reviewed

...

Many of the existing pavers on the pool deck are cracked

...

...

The failed waterproofing is causing major structural damage to the concrete structural slab below these areas "

55

SU SLAB SOFFIT REPAIR
1 1/2" x 1 1/2"

SF SLAB FULL-DEPTH REPAIR
1 1/2" x 1 1/2"

SE SLAB FULL-DEPTH DECK EDGE REPAIR
1 1/2" x 1 1/2"

ST SLAB TOP SURFACE REPAIR
1 1/2" x 1 1/2"

CS COLUMN SPALL REPAIR
1 1/2" x 1 1/2"

BT BONDED TOPPING TERMINATION
1 1/2" x 1 1/2"

EI STRUCTURAL CRACK REPAIR (EPOXY INJECTION)
1 1/2" x 1 1/2"

JS NON-STRUCTURAL CRACK REPAIR (CRACK SEALANT)
1 1/2" x 1 1/2"

CHAMPLAIN TOWERS SOUTH CONDOMINIUM SOUTH BUILDING
PHASE III OVERALL BUILDING REPAIR AND RESTORATION

morabito consultants

Project No. 042921
Scale: 1 1/2" = 1'-0"
Sheet Title: CONCRETE REPAIR DETAILS
Sheet No. S2C-2.1

56

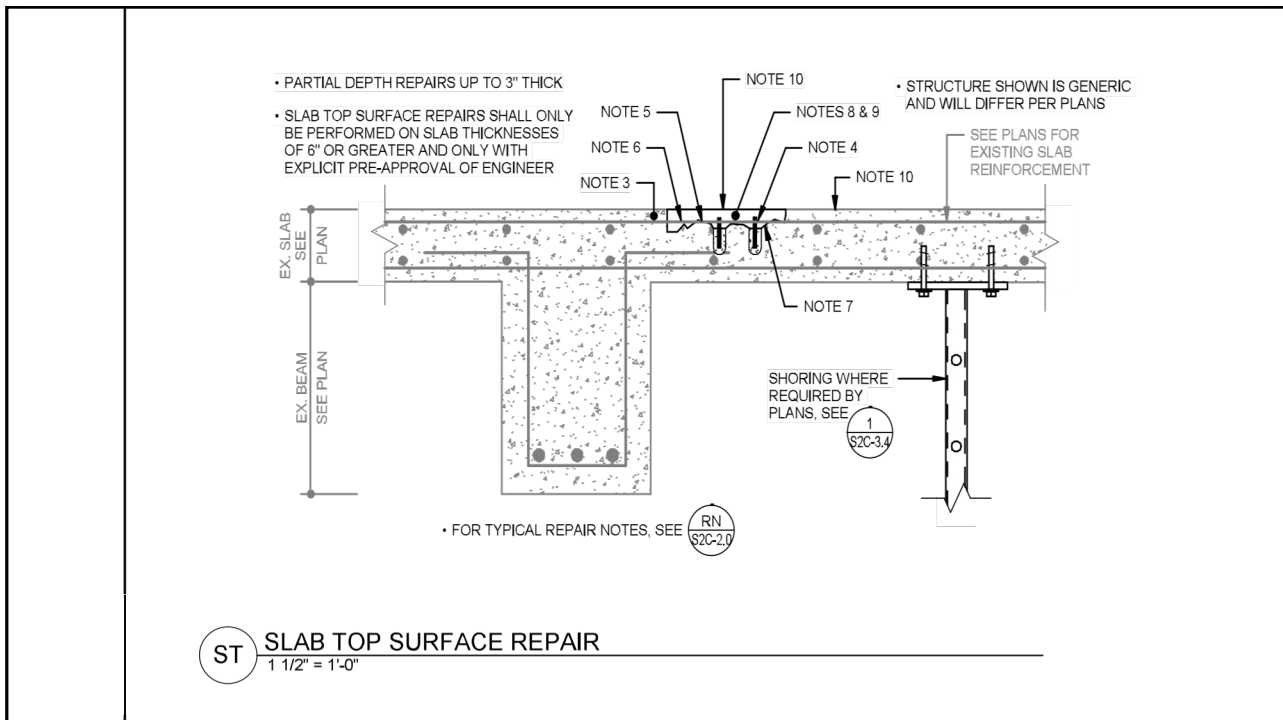

57

- ❖ Pacometría – posição das armaduras
- ❖ Esclerometria - dureza superficial
- ❖ Ultrasonido – ninhos de concretagem
- ❖ Testigos - f_c concretos
- ❖ Espessura de cobrimento
- ❖ Espessura de carbonatação
- ❖ Presença de perfil de cloretos
- ❖ Geometria e desenho de fissuras
- ❖ Identificação de áreas mais problemáticas



58

SurfSide MIAMI 2021 12 pavimentos

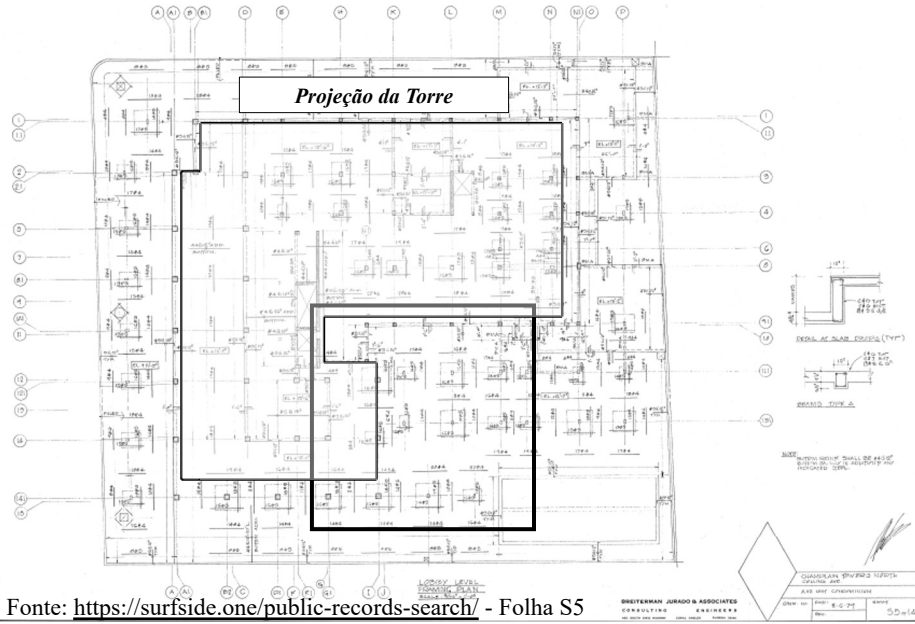

Fonte: <https://surfside.one/public-records-search/> - Folha S5

59

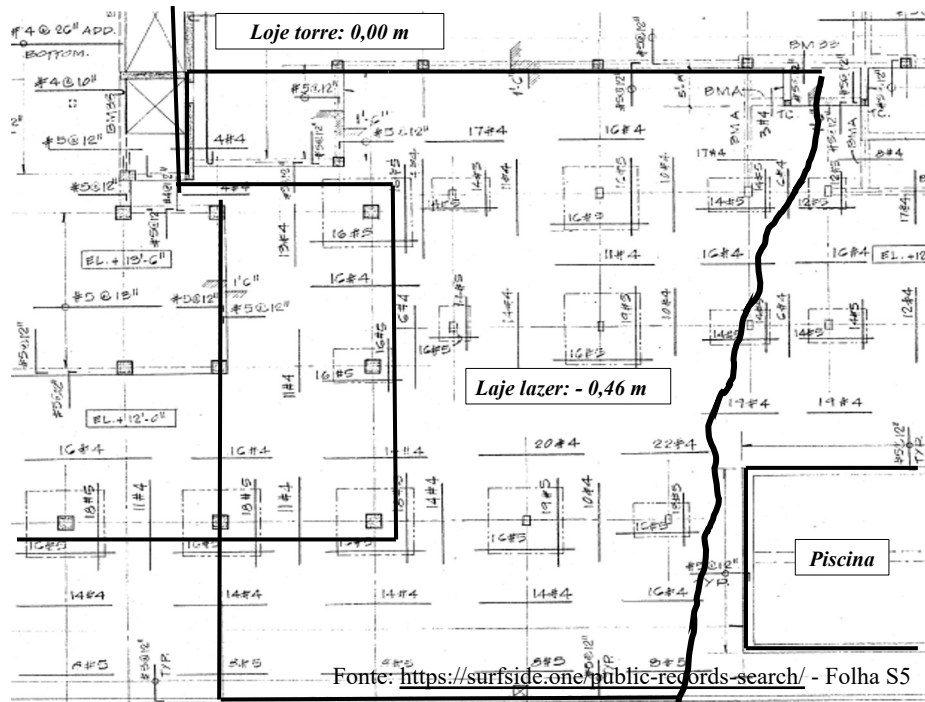

Fonte: <https://surfside.one/public-records-search/> - Folha S5

60

- ✓ Pilares de concreto da garagem até o terceiro andar: 6000psi (41.4 MPa)
- ✓ Lajes de concreto de pavimento tipo: 4000psi (27.6 MPa)
- ✓ Armadura do pilar 61x61cm : 12Ø32 → As=98.28cm²
→ρ=2.64%
- ✓ Armadura do pilar 41x41 cm : 8Ø36 → As=80.48cm²
→ρ=4.79%
- ✓ Armadura do pilar 36x46 cm: 10Ø32→As=81.9cm²
→ρ=4.95%
- ✓ Espessura das lajes: 25cm (térreo), 20cm (tipo)
- ✓ Armadura das lajes, face inferior: Ø12.7 C/30cm→ ρ=0.17% (planta baja), 0.19% (tipo)

Fonte: <https://surfside.one/public-records-search/> - Folhas S14 e S6

61

$f_{ck} = f_c$ dos pilares de cada pavimento

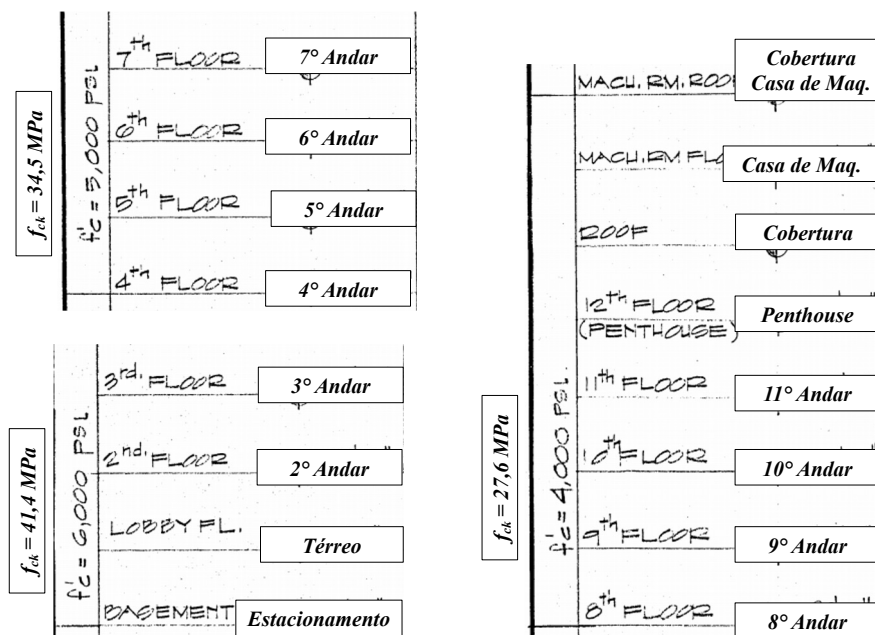

Fonte: <https://surfside.one/public-records-search/> - Folha S14

62

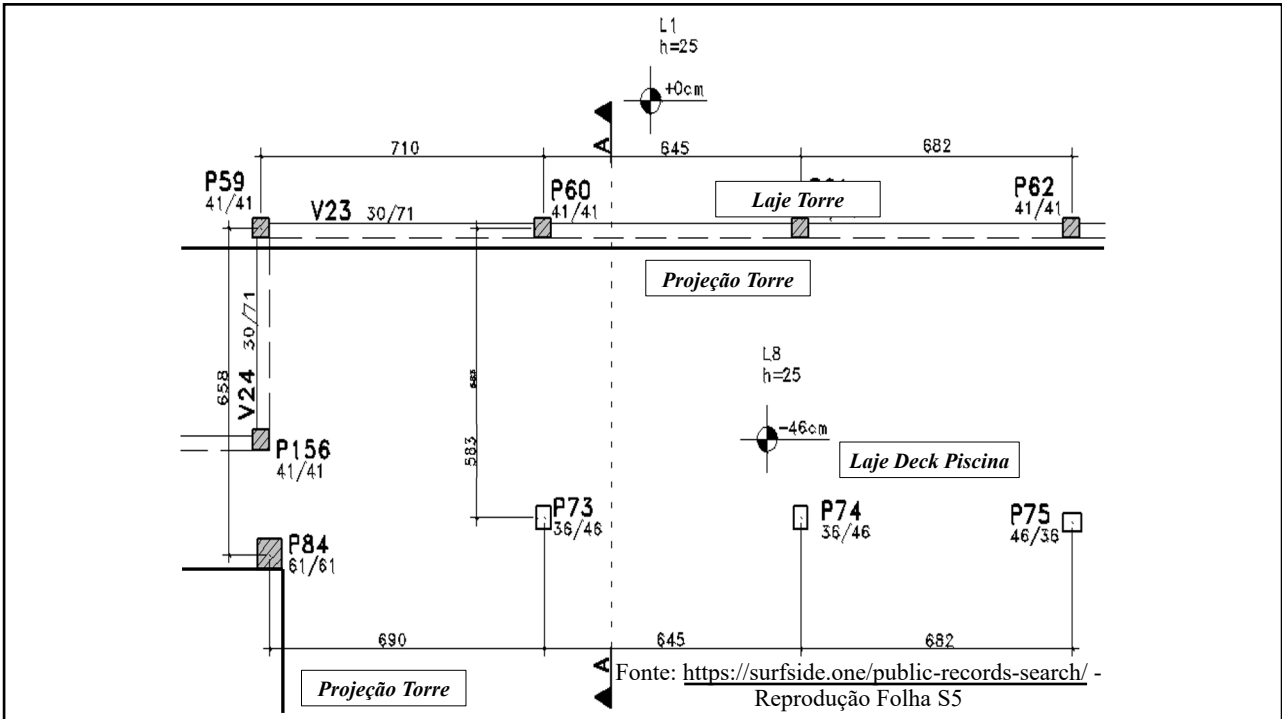

63

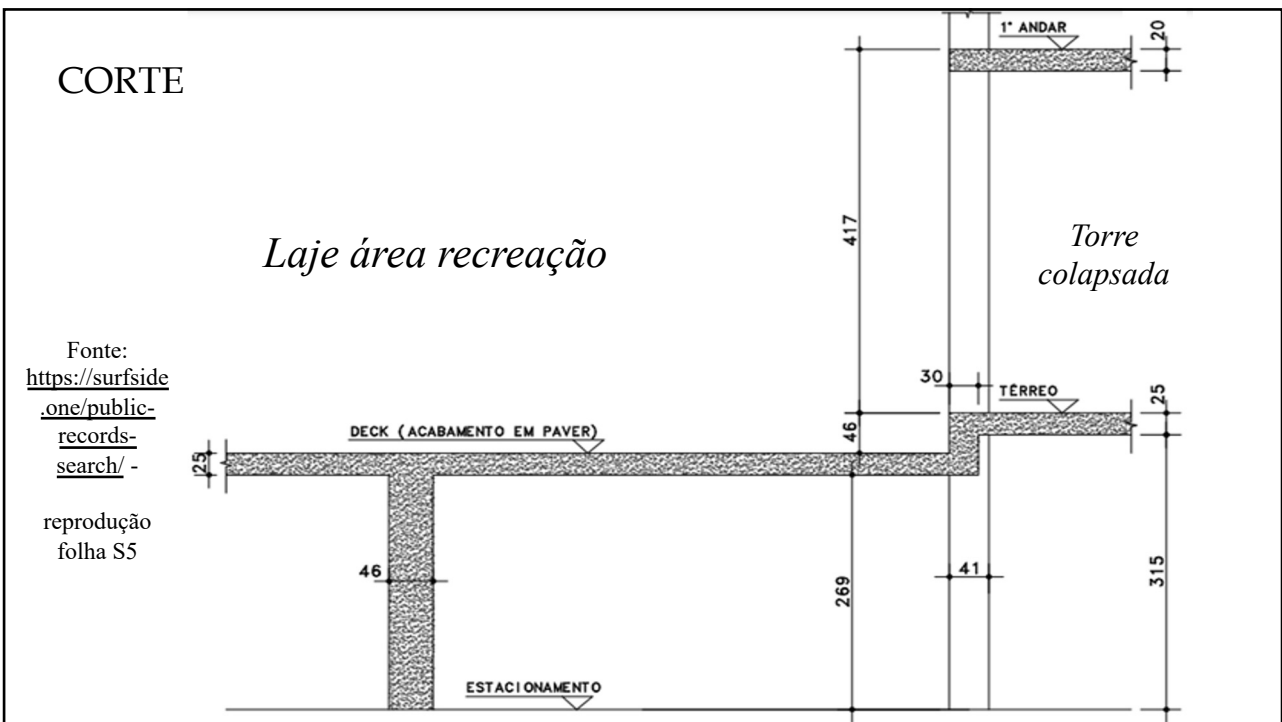

64

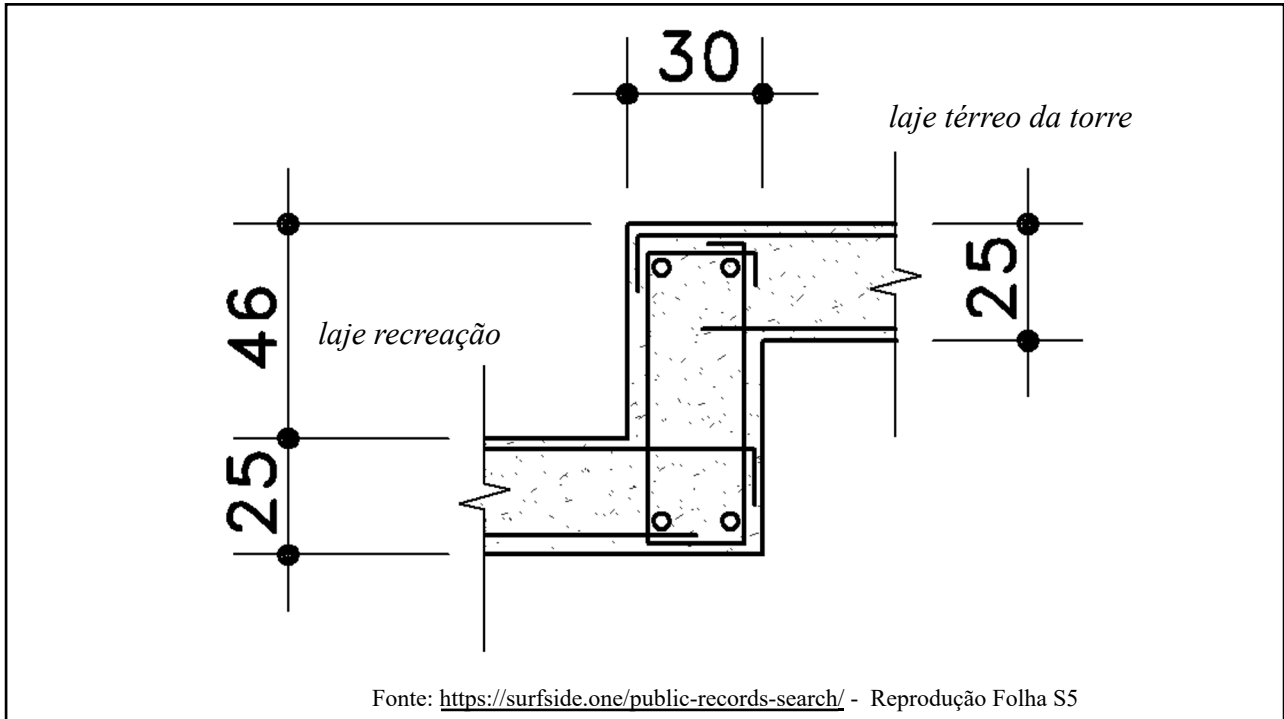

65

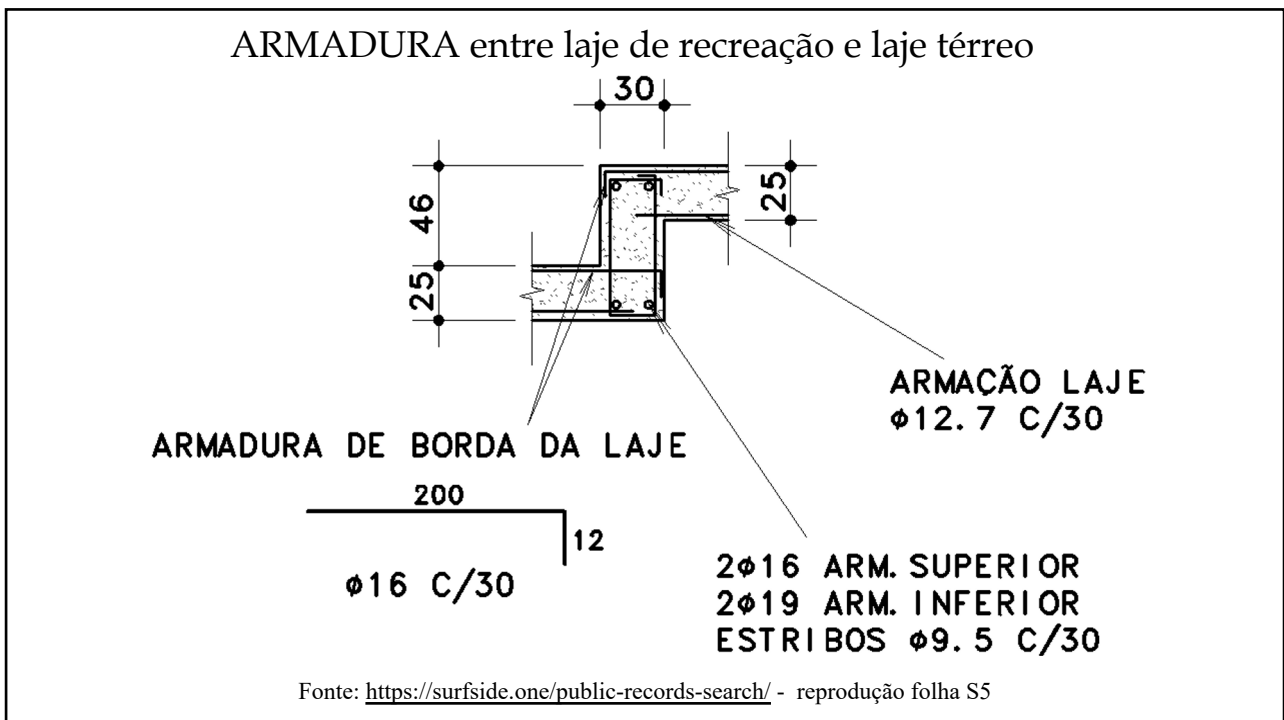

66

ARMADURA SUPERIOR PILAR 61x61 cm

Laje recreação sob torre que não há colapsado mas laje sim, colapsou

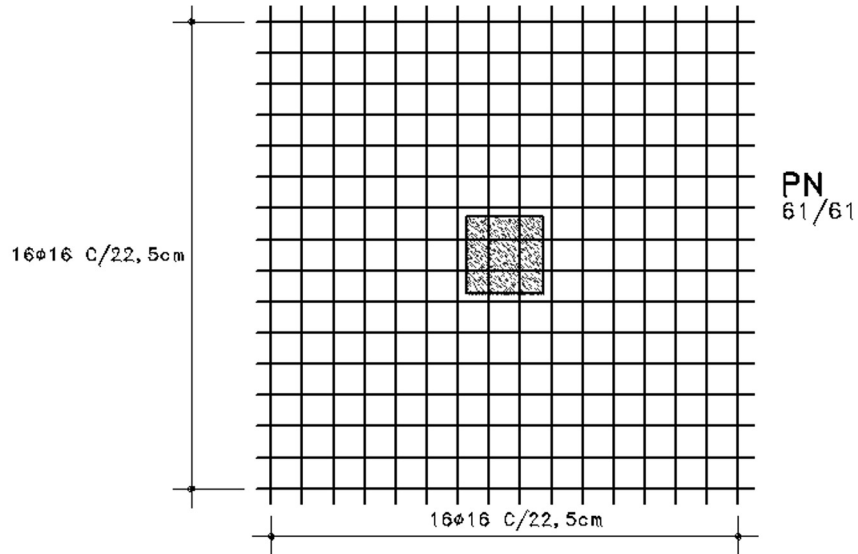
Fonte: <https://surfside.one/public-records-search/> - Reprodução Folha S5

67

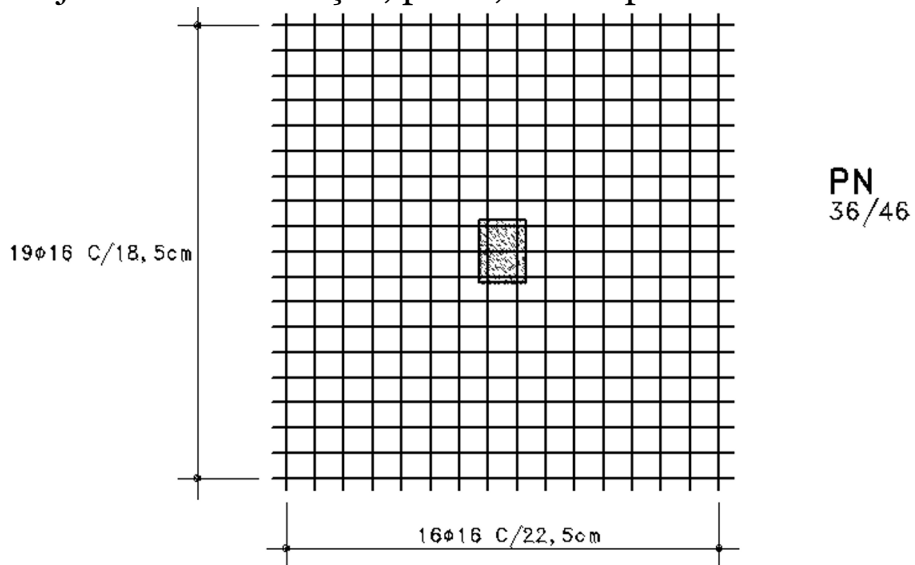
Armadura SUPERIOR pilares 36x46 cm
Laje área de recreação, plana, sem capitelFonte: <https://surfside.one/public-records-search/> - Reprodução Folha S5

68



Fonte: Acervo PhD. Capitel com armadura de punção ("estribos")

69

CORTE TÍPICO NAS ARMAÇÕES DE PUNÇÃO E COLAPSO PROGRESSIVO (SEM CAPITEL)

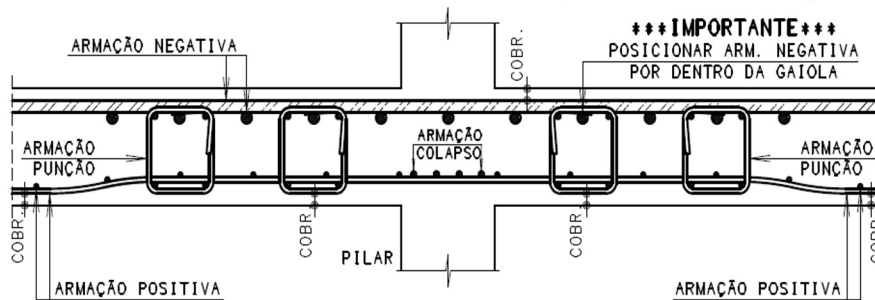

DETALHE DE AMARRAÇÃO NOS ESTRIBOS

AS BARRAS LONGITUDINAIS DEVEM ESTAR RIGOROSAMENTE ENCOSTADAS E AMARRADAS NOS QUATRO CANTOS DOS ESTRIBOS

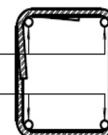

Fonte: Ricardo França & Associados

70

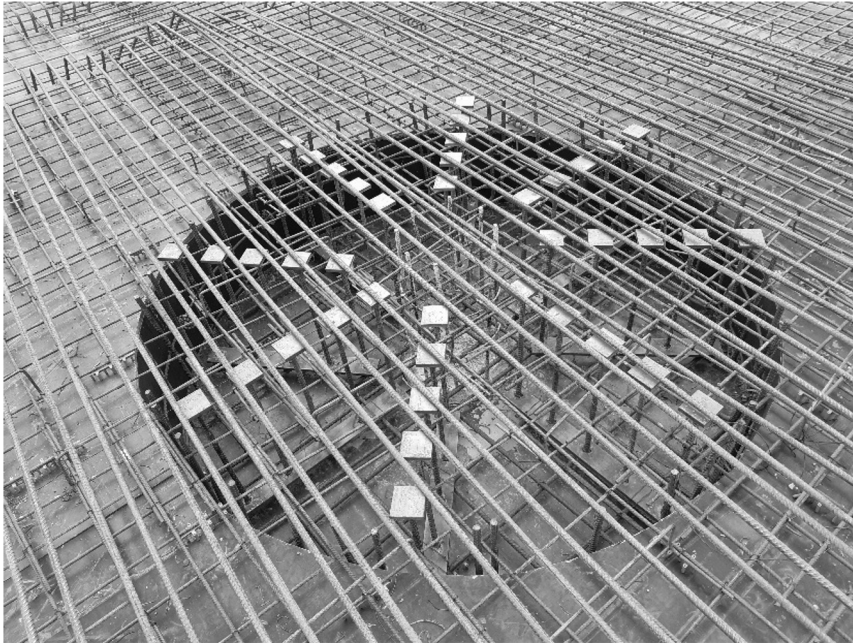

Fonte: Acervo PhD. Capitel com armadura de punção (“studs”).

71

Pilares colapsados



Fonte: <https://www.nist.gov/disaster-failure-studies/champlain-towers-south-collapse/news-and-updates->

72

Pilar colapsado

Fonte:
[https://www.nist.gov/
disaster-failure-
studies/champlain-
towers-south-
collapse/news-and-
updates-](https://www.nist.gov/disaster-failure-studies/champlain-towers-south-collapse/news-and-updates-)



73

Lajes



Fonte: [https://www.nist.gov/disaster-failure-studies/champlain-towers-south-
collapse/news-and-updates-](https://www.nist.gov/disaster-failure-studies/champlain-towers-south-collapse/news-and-updates-)

74



Laje
punção

Fonte:
<https://www.nist.gov/disaster-failure-studies/champlain-towers-south-collapse/news-and-updates->

75

apartado 20.12

“Punzonamiento”

pág. 418 a 422

Hormigón Armado

14^o Edición

Basada en la EHE

Publicada em 2000

Pedro Jiménez Montoya

Álvaro García Meseguer

Francisco Morán Cabre



76

Laje Recreação Piscina → Punção

$e_{\text{nominal}} = 25 \text{ cm} \rightarrow \text{canto} \rightarrow d = 22 \text{ cm}$

Carga peso próprio = 625 kgf/m^2

Carga Permanente = 450 kgf/m^2 Total : 1300 kgf/m^2

Carga Acidental = 225 kgf/m^2

Pilares $36 \text{ cm} \times 46 \text{ cm}$ a cada $6,5 \text{ m}$ por $7,0 \text{ m}$

Superfície crítica $\rightarrow 2,5 \text{ m}^2 \rightarrow \text{carga no pilar} = 55000 \text{ kgf}$

$f_{ck} = 27,6 \text{ MPa (N/mm}^2)$

Taxa armadura = $0,01$ coeficiente $\beta = 1,15$

Normal solicitante $\rightarrow F_{sd} = 550 * \gamma_F$ (kN)

Perímetro crítico $\rightarrow \mu_1 = 440 \text{ cm}$

Fonte: <https://surfside.one/public-records-search/> - Folhas S5, S6 e S14

77

Laje Recreação Piscina → Punção

$$\tau_{rd} = 0,12 * \left(1 + \sqrt{\frac{200}{d}}\right) * \sqrt[3]{(100 * \rho_l * f_{ck})}$$

$$\tau_{sd} = \frac{\beta * F_{sd}}{\mu_1 * d}$$

*hipótese de
corrosão de
armadura*

78

Laje Recreação Piscina → Punção

$$\tau_{sd} = \tau_{rd}$$

$$\tau_{rd} = 0,70 \text{ N/mm}^2 \text{ (MPa)}$$

$$\tau_{sd} = 0,65 * \gamma_F$$

(1,4 ?!)

$$\gamma_F = 1,08$$

(1,5 ?!)

*hipótese de
corrosão de
armadura*

79

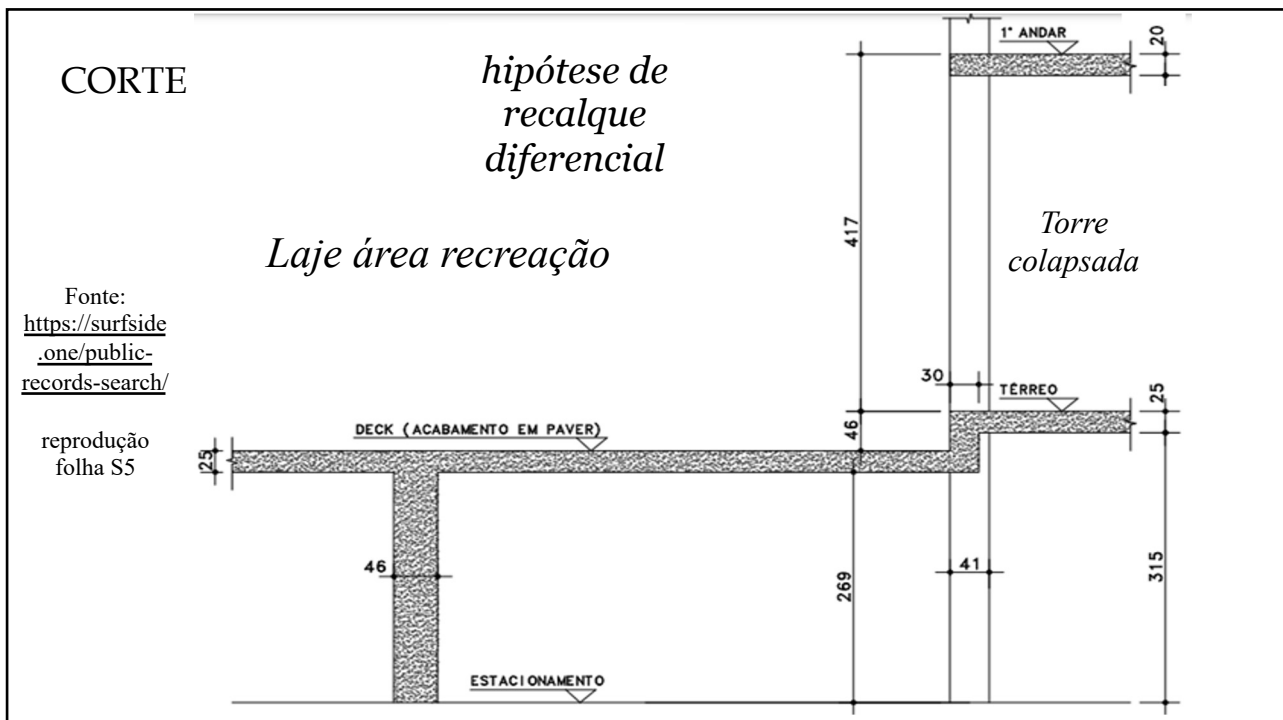

80

Laje Recreação Piscina → Punção

Superfície crítica → 2,5 m² → carga no pilar = 55000 kgf

Recalque 1mm → carga extra no pilar ≈ 2800 kgf

$$\tau_{rd} = 0,70 \text{ N/mm}^2 \text{ (MPa)}$$

$$\tau_{sd} = 0,68 * \gamma_F$$

$$\gamma_F = 1,03$$

*hipótese de
recalque
diferencial*

81

Laje Recreação Piscina → Punção

Superfície crítica → 2,5 m² → carga no pilar = 55000 kgf

Recalque 2mm → carga extra no pilar ≈ 5300 kgf

$$\tau_{rd} = 0,70 \text{ N/mm}^2 \text{ (MPa)}$$

$$\tau_{sd} = 0,71 * \gamma_F$$

$$\gamma_F = 0,99$$

*hipótese de
recalque
diferencial*

82

Lições Aprendidas

- ❖ Nossas condolências e solidariedade com as famílias envolvidas
- ❖ ATP (Análise Técnica de Projeto. revisão de projeto estrutural por pares)
- ❖ ATO (Acompanhamento Técnico da Obra. controle tecnológico das estruturas)
- ❖ ATU (Avaliação Técnica de Uso. inspeção periódica e competente)
- ❖ Manutenção (realização de obras)
- ❖ Cuidado com a água! Nunca subestime o risco de corrosão!
- ❖ Edifícios não são eternos, os problemas podem tardar anos
- ❖ Escolher profissionais bem preparados para inspecionar (certificação de pessoal)
- ❖ O último engenheiro universal foi Leonardo da Vinci (equipe multidisciplinar)

83



84