



Aprendendo com Acidentes



Paulo Helene

Diretor PhD Engenharia

Presidente e Conselheiro Permanente IBRACON

Prof. Titular Universidade de São Paulo

Gestor e Ex-Presidente ALCONPAT Internacional

Member fib(CEB-FIP) Model Code for Service Life Design

Conselheiro da CNTU e SEESP

IDD

13 de fevereiro de 2023

Curitiba.SCI

1

Torres Champlain Towers South

8777 Collins Avenue, Miami Surfside

Inauguração 1981, investidor/construtor Nathan Reiber

Champlain Towers North, 1981 & Champlain Towers East, 1994

Formato L com 12 andares

Colapso 01h 30

24 de Junho de 2021 40 anos de idade

98 mortos

2

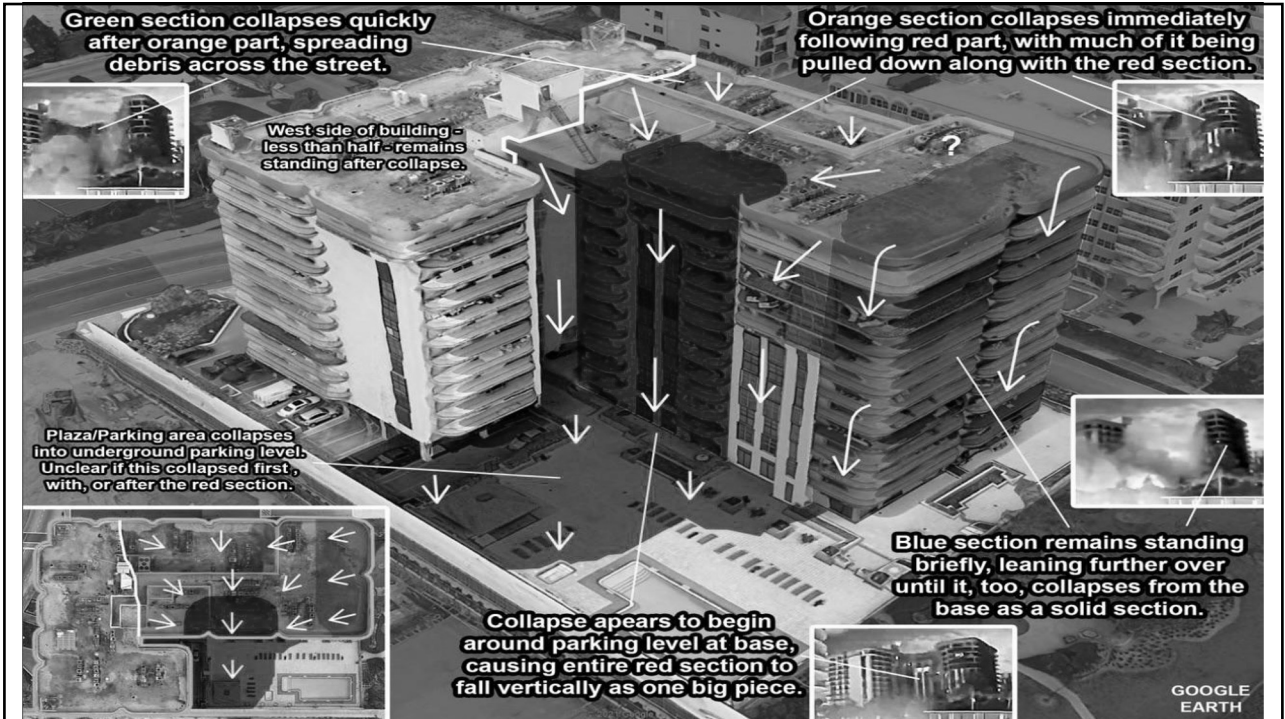

3

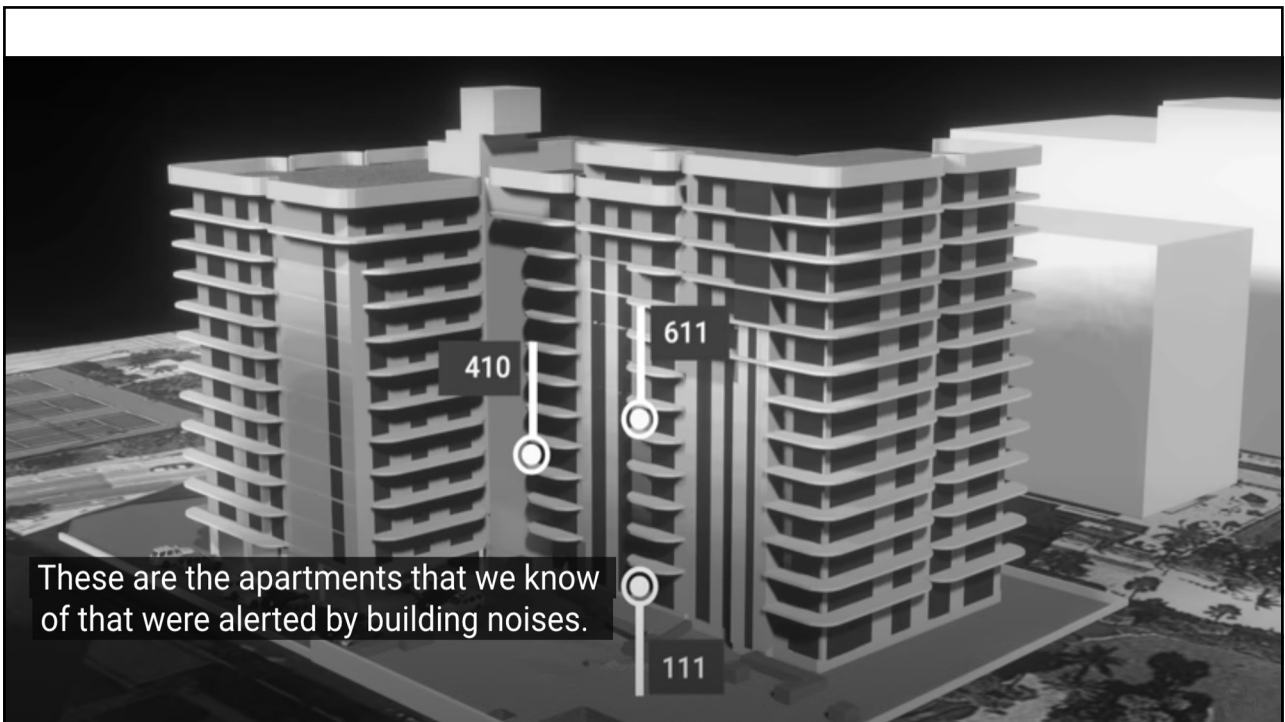

4

Una residente dijo a *The Post* que minutos antes de que se derrumbara **Champlain Towers South** en **Surfside**, se dio cuenta de que una sección de la cubierta de la piscina y una zona de aparcamiento a nivel de la calle se habían derrumbado. El marido de otra residente ha dicho que su esposa, que no ha sido vista desde el desastre, hizo una observación similar en una llamada telefónica poco antes del colapso.

Sara Nir, una residente, dijo a *The Post* que poco antes de la 1 de la madrugada notó fue ruidos de “**golpes**” que supuso eran causados por las obras de construcción. Alrededor de la 1:14 de la madrugada, oyó un ruido que le pareció el de un muro que se derrumbaba, y salió de su apartamento de la planta baja para quejarse a un guardia de seguridad en el vestíbulo.

5

Primeira Lição

Fique atento e escute os gritos da estrutura, pois podem ocorrer acidente graves e colapsos em qualquer idade da estrutura.

Todas as estruturas advertem que estão prestes a colapsar, e o desafio é saber interpretar os sinais da estrutura!

Isomente aqueles que entenderam os avisos foram salvos!

6

South Florida apartment building evacuated after engineers deem it structurally unsafe

By Amanda Musa and Melissa Alonso, CNN

Updated 1733 GMT (0133 HKT) April 5, 2022



More From CNN



Doja Cat stuns at Grammys red carpet in dreamy Versace gown



Rare black lion tamarin born at Jersey Zoo

REPERCUSSÕES

7

Related Article: After Surfside tower collapse, condo residents in Florida and beyond wonder if they should worry

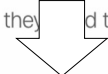

In July, North Miami Beach ordered the evacuation of a 10-story building, Crestview Towers, after a report determined the building's structure to be unsafe. The residents have not yet returned, Cabrera said.

"The residents at Crestview have not been allowed back to the property because the structural repairs just started two weeks ago," Cabrera told CNN. "The electrical repairs have not started yet. Therefore, the building is still unsafe until the property completes the repairs needed for re-occupancy."

belongings. The city will schedule a time for residents to come back later this week to pick up heavier furniture and large items," Cabrera said in an email to CNN.

USA company, Live in São Paulo
Find Jobs Online | Search Ads

254x282x400cm
Marrom Material Leroy Merlin

SPONSORED CONTENT

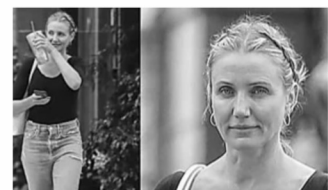

E num piscar de olhos, eles deixaram de ser celebridades

Investing.com - BR

Recommended by Outbrain

REPERCUSSÕES imediatas !

PAID CONTENT

Smartfeed

8



9

NIST encourages members of the public to submit any information, including video, photos or other documentation

- ✓ June 24, 2021, Champlain Towers South, 12-floor condominium in Surferside, Florida, at 1:30 a.m.
- ✓ June 25, NIST began a team of six scientists and engineers to collect firsthand information on the collapse.
- ✓ June 30 decided full technical investigation of the collapse by National Construction Safety Team (NCST) Act
- ✓ NCST's work will not interfere with the ongoing search-and-rescue operation at the scene of the collapse.
- ✓ NCST's role is not to determine any culpability.
- ✓ NCST investigation is to determine the technical diagnose and cause of the collapse and, learning from that, to recommend changes to building codes, standards and practices, and appropriate actions to improve the structural safety of buildings.

10



Inspeções e Amostragem

recolheram para análise em laboratório cerca de 200 elementos construtivos

11

Segunda Lição

- ✓ Transparência → criar um portal de acesso público com todas as informações e fotos
- ✓ Valorizar a pesquisa tecnocientífica, junto com a polícia e bombeiros, desde o primeiro dia
- ✓ Nomear uma equipe multidisciplinar responsável, com poder e autonomia (“*Comitê de Crise do Buraco*”)

“públicas e privadas”

12

Sobre a sequência do colapso há consenso:

1. laje de recreação
2. 1ª parte da torre
3. 2ª parte da mesma torre
4. 3ª parte da mesma torre
5. parte lateral da torre



13

...então qual a dúvida?

Qual foi o gatilho?

Porquê uma parte se propagou à outra?

Porquê depois de 40 anos?

14

<https://surfside.one/public-records-search/>

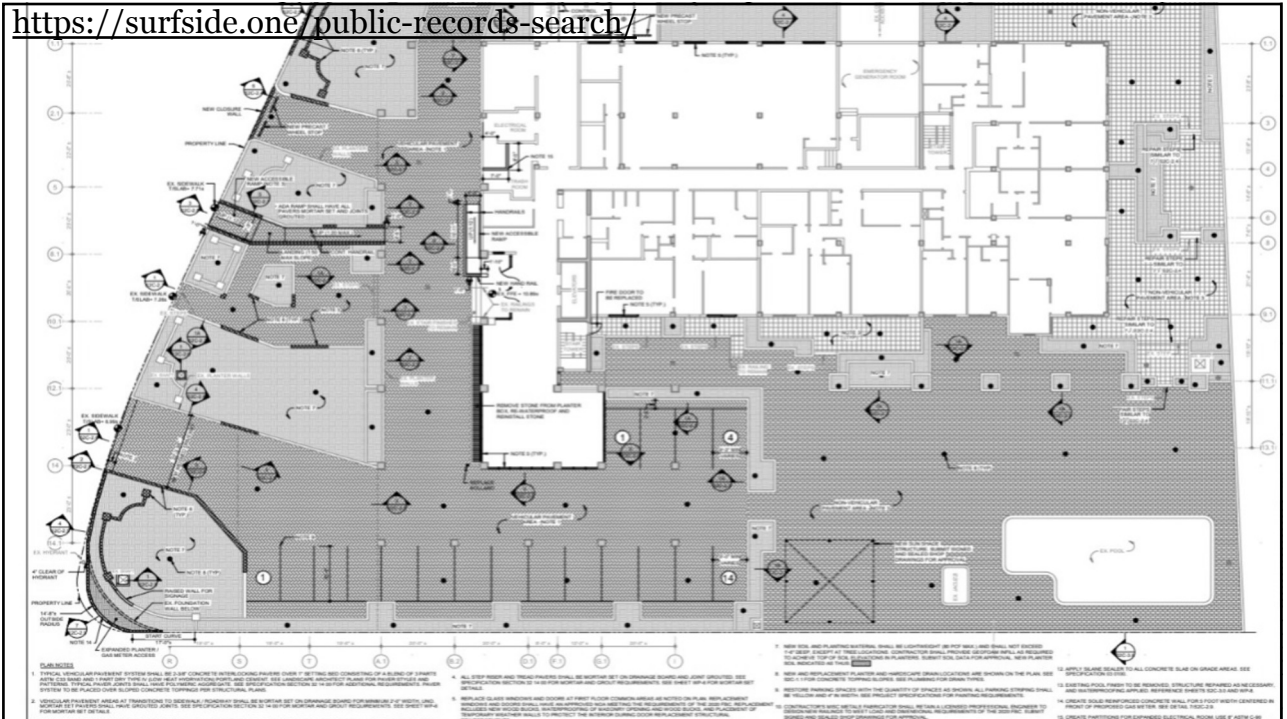

15

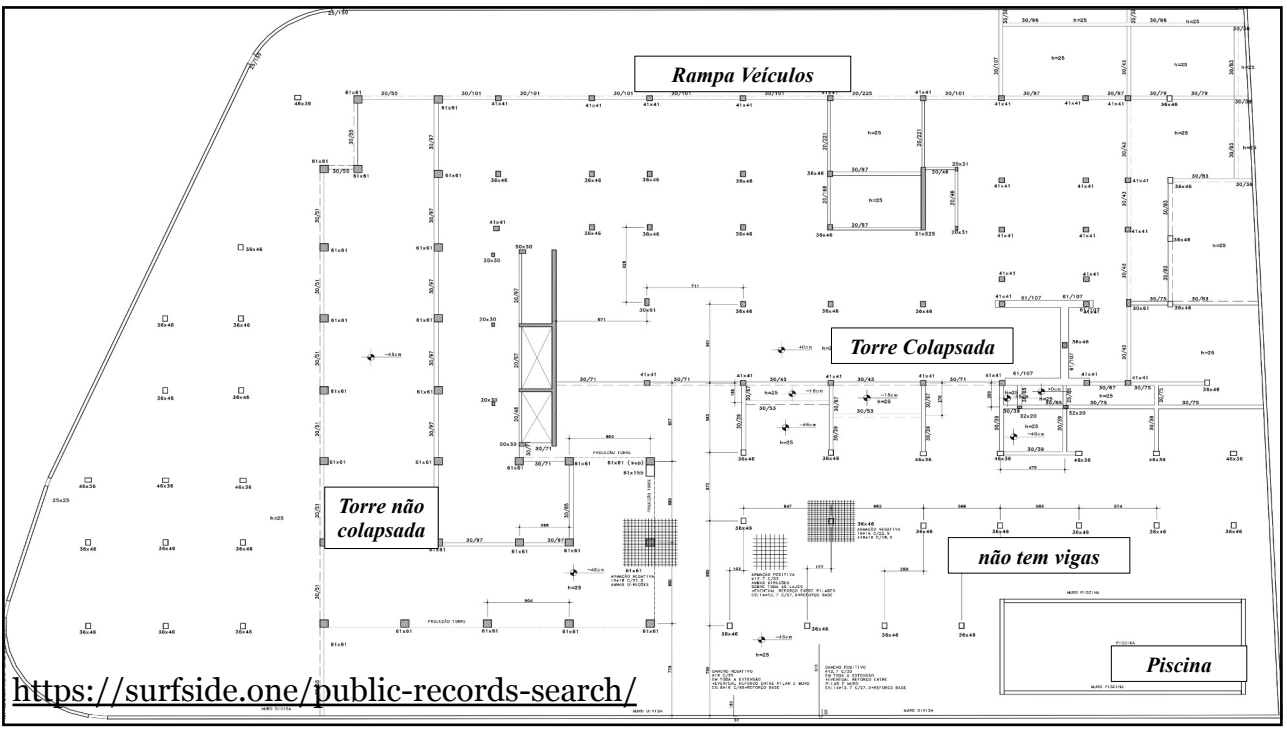

<https://surfside.one/public-records-search/>

16

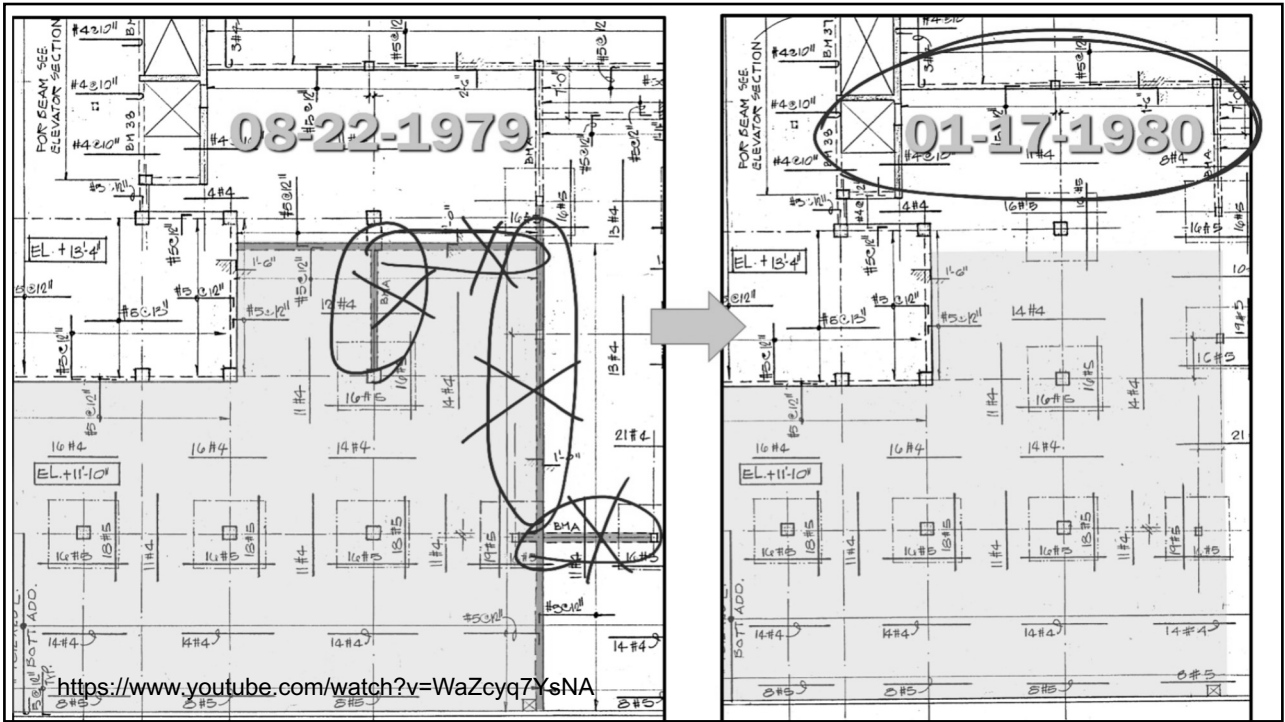

17

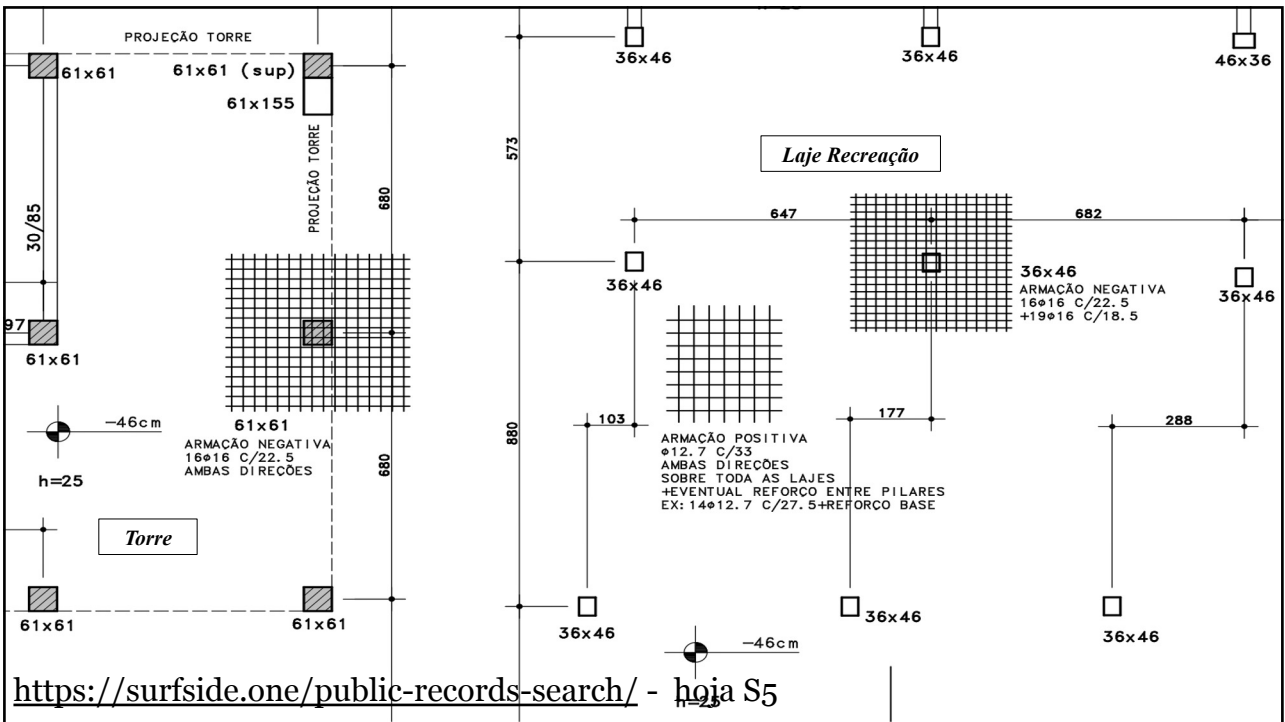

18

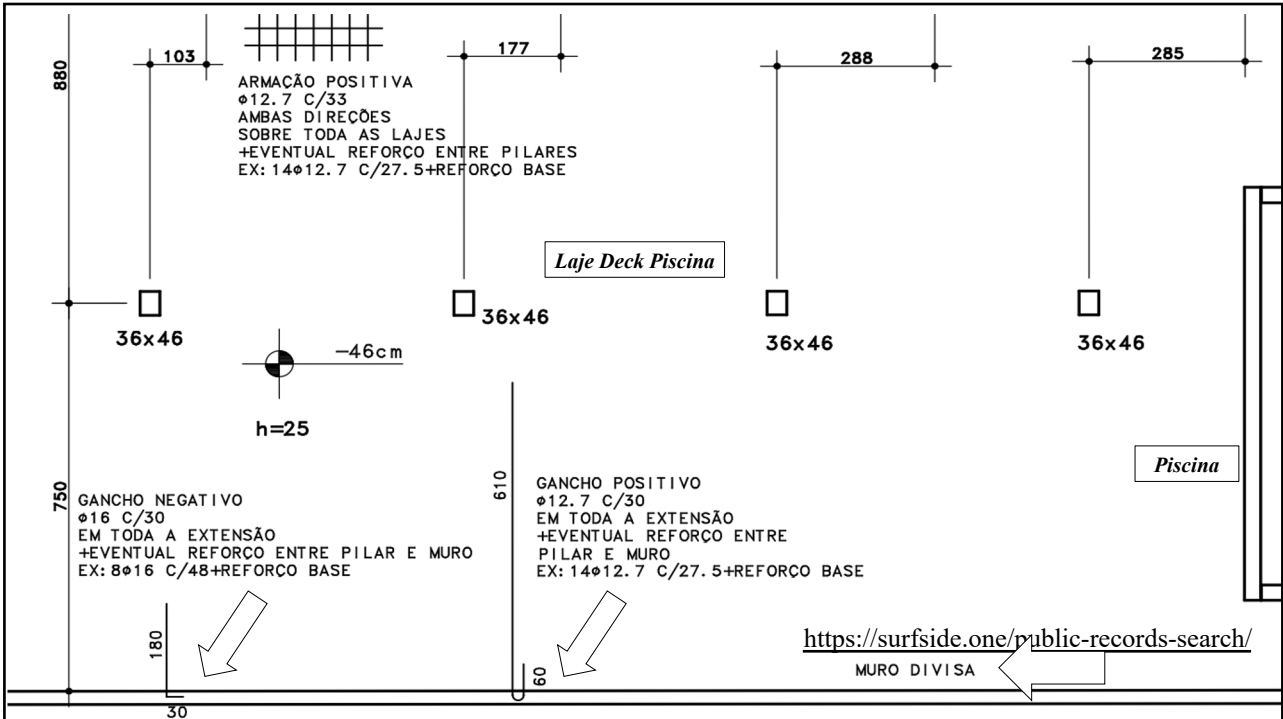

19



20

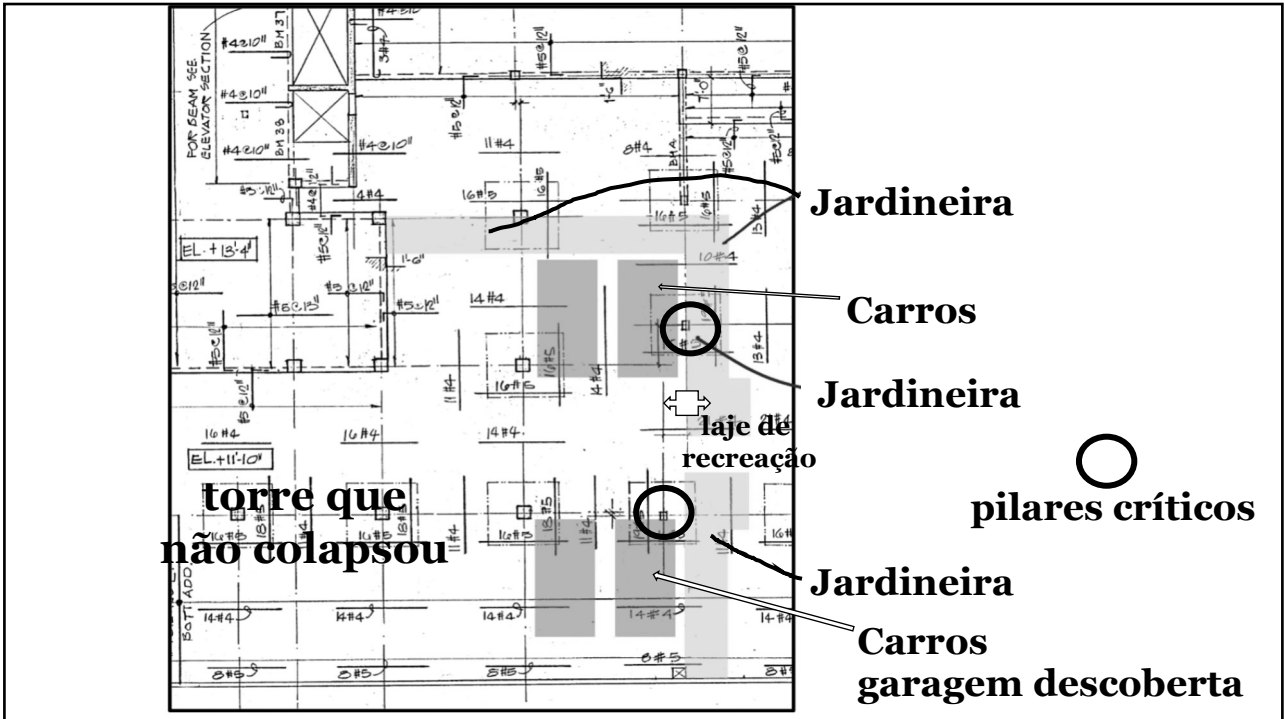

21

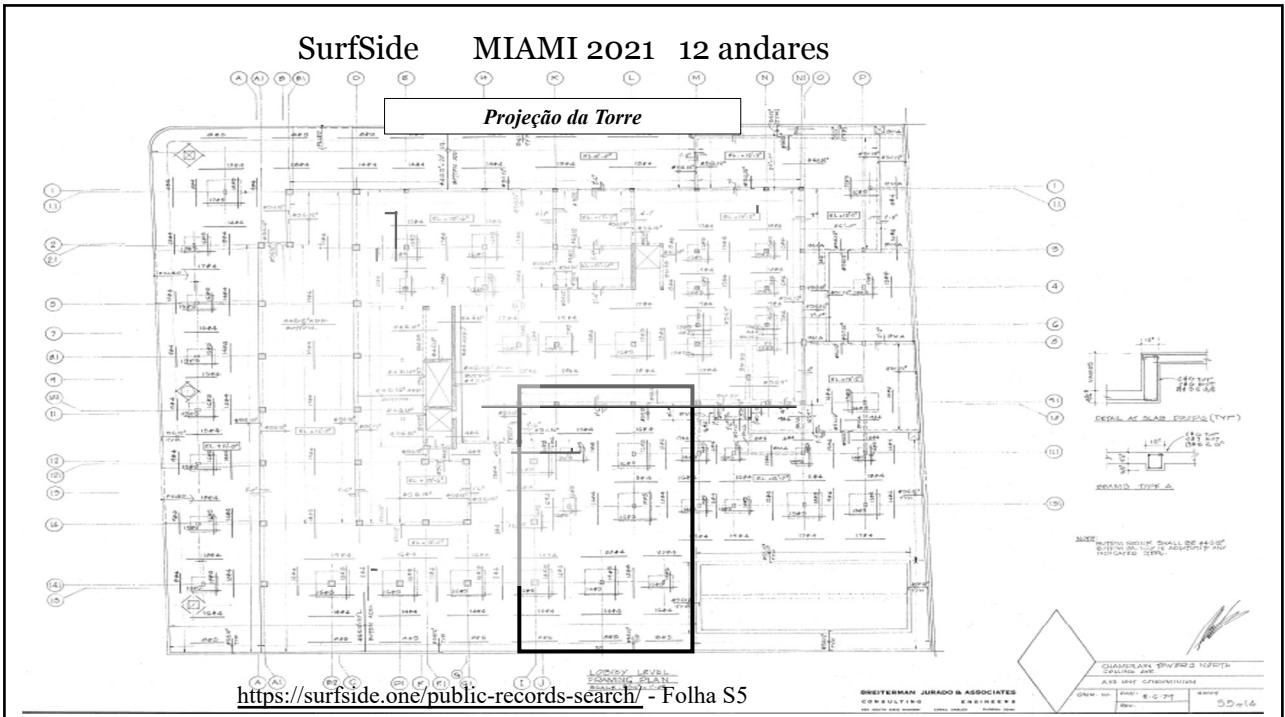

22

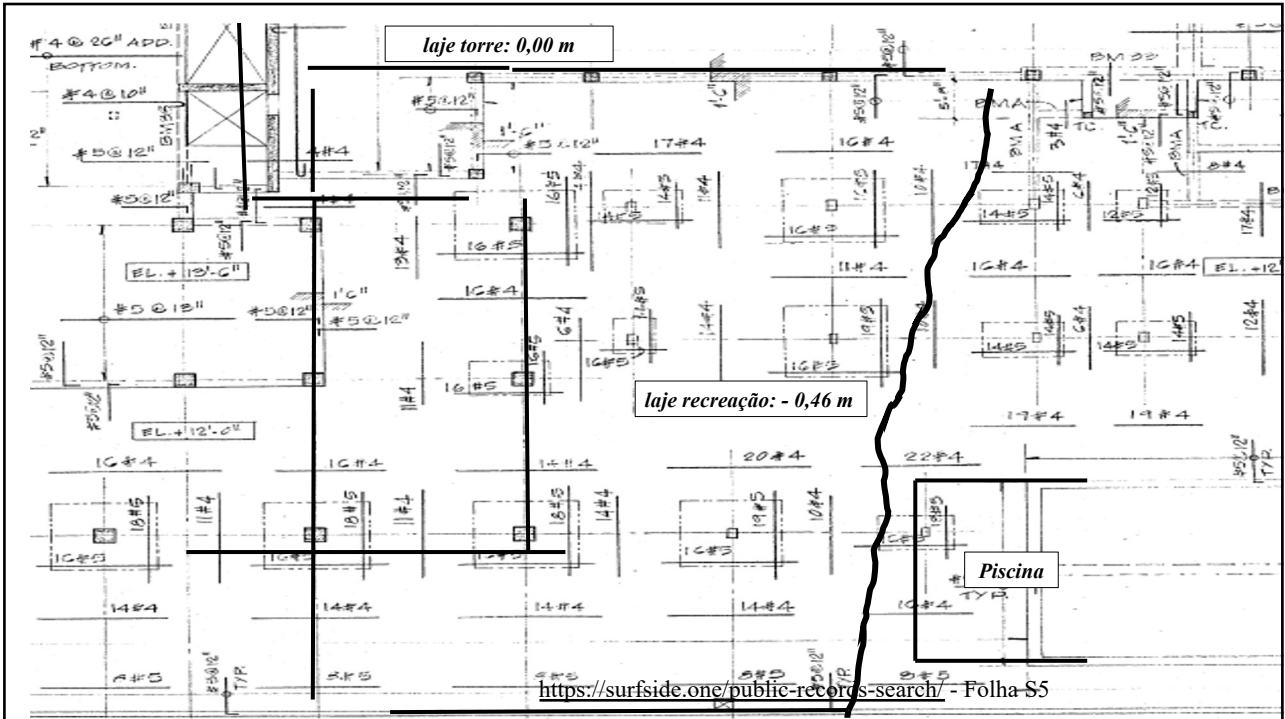

23

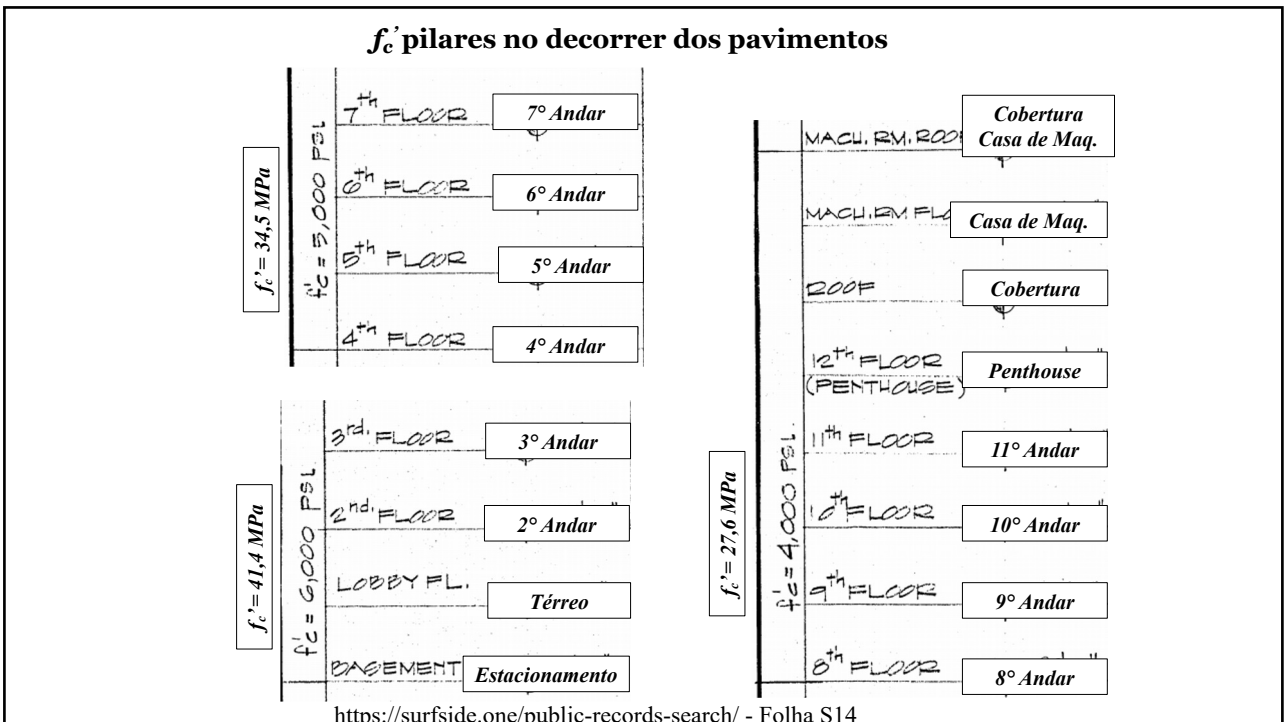

24

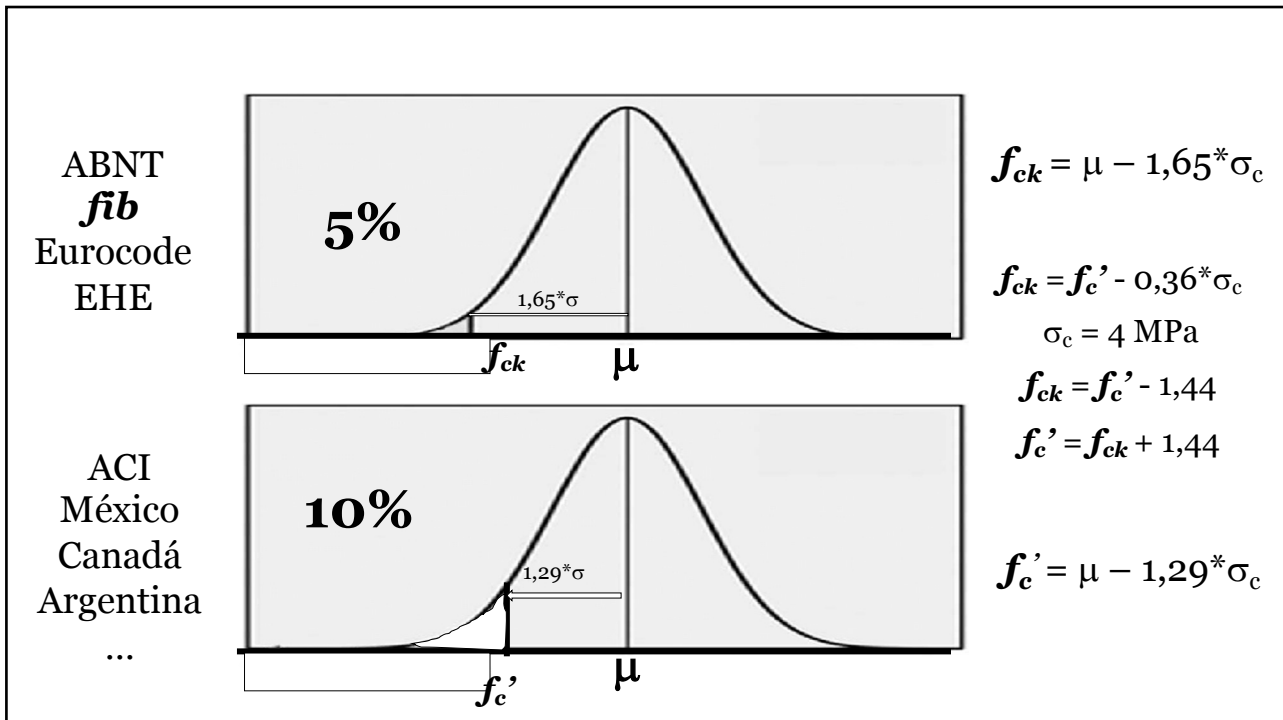

25

- ✓ Concreto pilares da garagem até o terceiro andar: 6.000psi (41,4 MPa)
 - ✓ Concreto lajes até o 8 andar: 4.000psi (27,6 MPa)
 - ✓ Armadura pilar 61x61cm : 12Ø32 → As=98,28cm² → ρ=2,64%
 - ✓ Armadura pilar 41x41 cm : 8Ø36 → As=80,48cm² → ρ=4,79%
 - ✓ Armadura pilar 36x46 cm: 10Ø32 → As=81,9cm² → ρ=4,95%
 - ✓ Espessura lajes: 25cm (térreo), 20cm (tipo)
 - ✓ Armadura inferior lajes: Ø12,7 C/30cm → ρ=0,17% (térreo), 0,19% (tipo)
 - ✓ Não foi encontrado em projeto detalhe de armadura de punção
- <https://surfside.one/public-records-search/> - Folhas S14 e S6

26



Pilares

<https://www.nist.gov/disaster-failure-studies/champlain-towers-south-collapse/news-and-updates->

27



Pilares

<https://www.nist.gov/disaster-failure-studies/champlain-towers-south-collapse/news-and-updates->

28



Pilares

<https://www.nist.gov/disaster-failure-studies/champlain-towers-south-collapse/news-and-updates->

29



Lajes

<https://www.nist.gov/disaster-failure-studies/champlain-towers-south-collapse/news-and-updates->

30



Lajes

<https://www.nist.gov/disaster-failure-studies/champlain-towers-south-collapse/news-and-updates->

31

Punção

ilustração

32



33

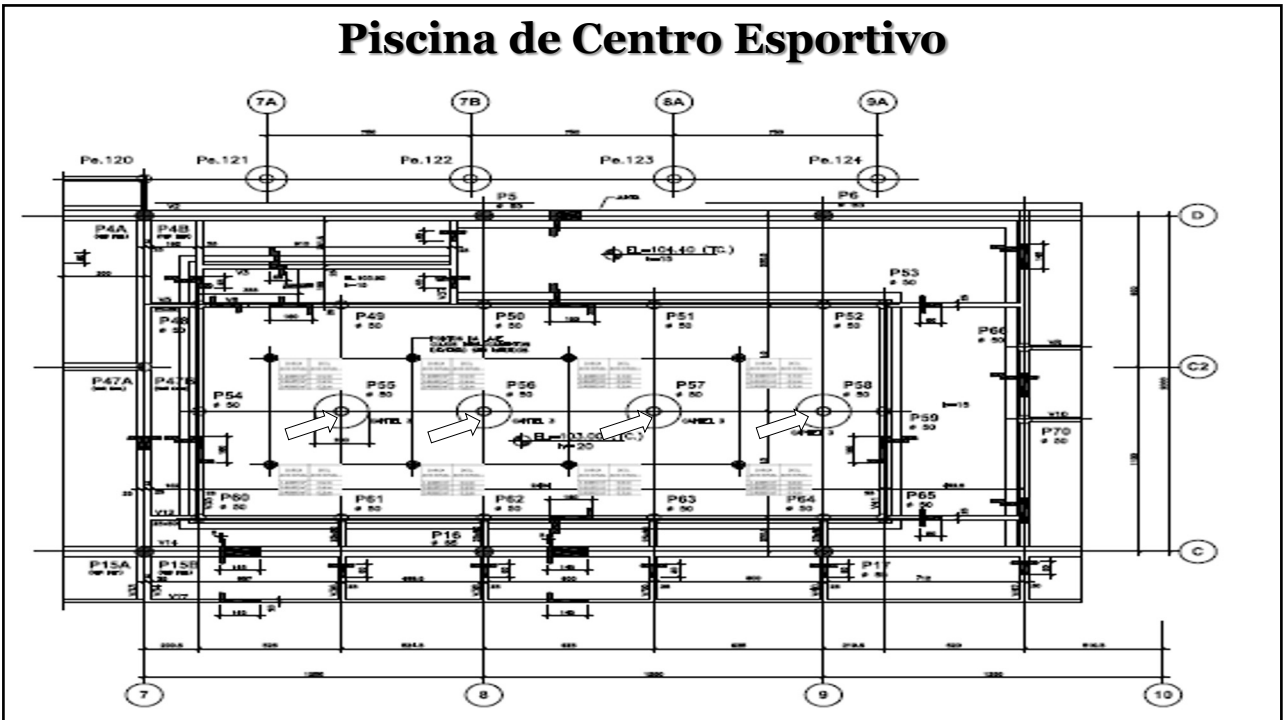

34



35



36



37



38

Paulo Helene

MANUAL PARA REPARO, REFORÇO E PROTEÇÃO DE ESTRUTURAS DE CONCRETO

Projeto de Divulgação Tecnológica

PINI Editora

FOSROC

Punção

Manifestação Típica

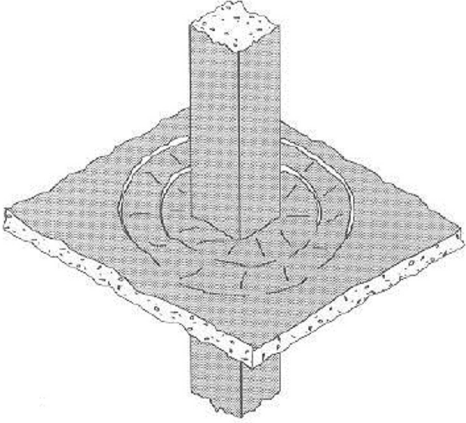

39



Laje

<https://www.nist.gov/disaster-failure-studies/champlain-towers-south-collapse/news-and-updates->

40

☰ MENU
G1
ESPÍRITO SANTO
TVG22E10

19/07/2016 09h49 - Atualizado em 19/07/2016 19h32

Área de lazer em condomínio de luxo desaba e porteiro é achado morto

Drone mostra o estrago no Grand Parc, na Enseada do Suá, em Vitória. Suspeita é de vazamento de gás, segundo Corpo de Bombeiros.

Wiviane Machado e Victoria Varejão
Do G1 ES

FACEBOOK
Twitter
Google+
Pinterest



As torres do condomínio de luxo Grand Parc Residencial Resort, na Enseada do Suá, em Vitória, foram esvaziadas após toda a **área de lazer desabar, na manhã desta terça-feira (19)**. Quatro pessoas ficaram feridas e **um porteiro ficou desaparecido até as 17h. Ele foi encontrado morto**. O desabamento aconteceu por volta de 3h.

<http://g1.globo.com/espírito-santo/noticia/2016/07/torres-de-condominio-de-luxo-no-es-sao-evacuadas-apos-desabamento.html>

Exemplo de acidente com punção mas, com robustez que evitou uma tragédia

41



42

<http://g1.globo.com/espirito-santo/noticia/2016/07/19/destroamento-em-condominio-fere-3-e-deixa-desaparecido-em-vitoria-es.html>



43



44



45



46

- 19.07.2016 (03 h)
- 6 anos de idade

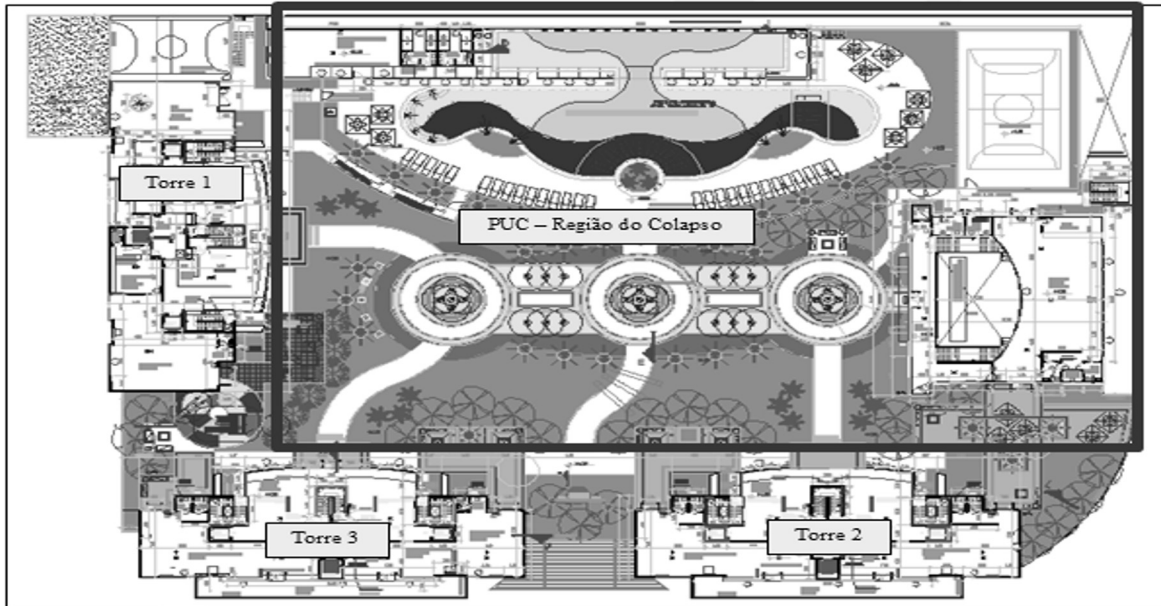

47

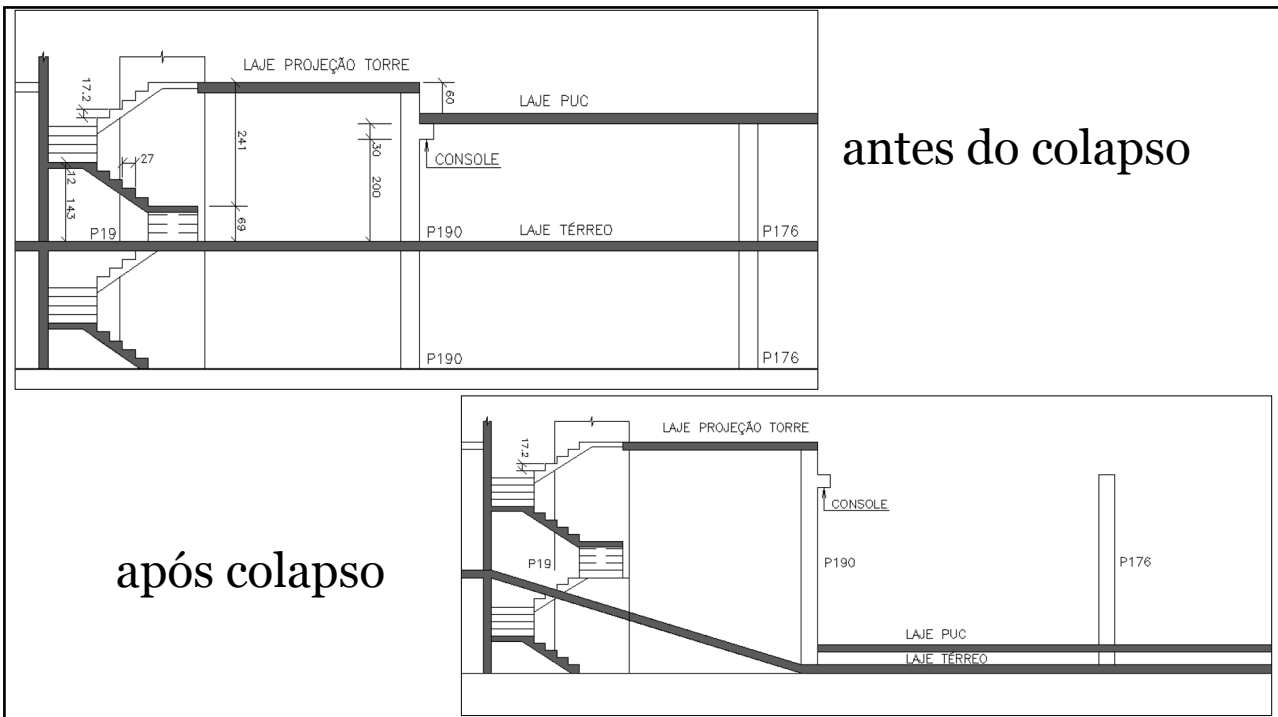

48



49



50



51



52



53

Hipóteses do “Gatilho”

1. Corrosão das armaduras dos pilares
2. Estrutura com lajes planas sem vigas
3. Efeitos ambientais de sumidouros
4. Corrosão de armadura da laje perto piscina

54

October 8, 2018

Re: *Champlain Towers South Condominium
Structural Field Survey Report
MC Job# 18217*

Page 8

O Relatório estrutural de Morabito, 2018, demonstra que a corrosão das armaduras nos pilares era inicial e jamais suficiente para justificar um colapso

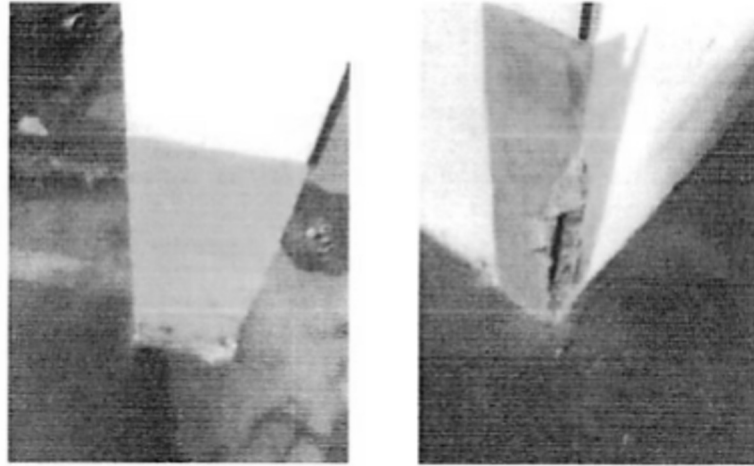

Figure J1: Typical cracking and spalling at parking garage columns

55



56



57

Hipóteses do “Gatilho”

1. Corrosão das armaduras dos pilares → Negativo
2. Estrutura com lajes planas sem vigas → Negativo
3. Efeitos ambientais de sumidouros
4. Corrosão de armadura da laje perto piscina

58



59

O geofísico **Mika McKinnon** apontou uma série de falhas no plano de **Elon Musk** para cavar túneis em **Miami**, como a sua empresa **The Boring Company** tem feito em várias outras cidades dos **Estados Unidos**. Em entrevista ao site *Curbed*, McKinnon explicou que o solo embaixo da cidade da Flórida é composto de um cárstico de calcário altamente dissolúvel, que é cheio de cavidades e cavernas – assim como o solo do oceano.



Esse seria o motivo pelo qual Miami não possui um sistema de metrô, e também porque a grande maioria das casas da cidade não tem porões. Essa característica geográfica também faz com que a cidade seja particularmente suscetível a inundações.

Por causa disso, ela necessita de um complexo sistema de bombeamento apenas para garantir que suas ruas são navegáveis por carros. Isso mesmo em épocas em que não há grandes tempestades na região.

60

Hipóteses do “Gatilho”

1. Corrosão das armaduras dos pilares → Negativo
2. Estrutura com lajes planas sem vigas → Negativo
3. Efeitos ambientais de sumidouros → Negativo
4. Corrosão de armadura da laje perto piscina

61

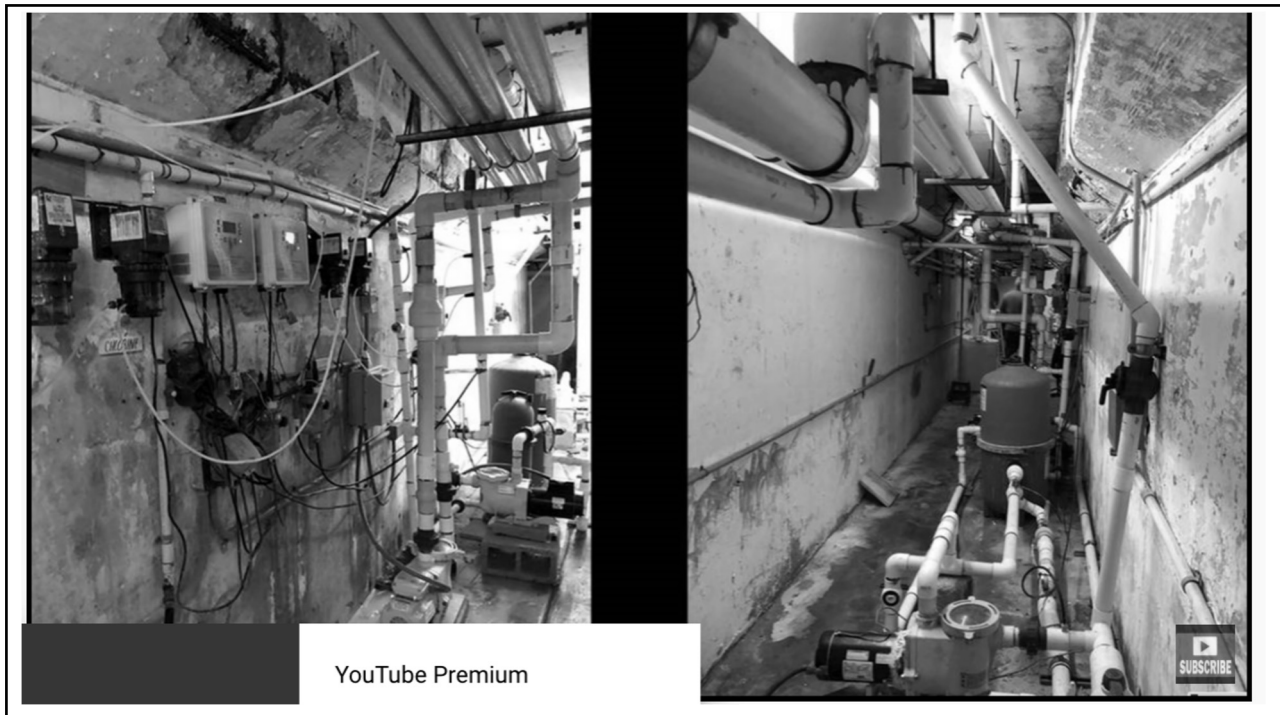

62



63

Hipóteses FALSAS do “Gatilho”

1. Corrosão das armaduras dos pilares → Negativo
2. Estrutura com lajes planas sem vigas → Negativo
3. Efeitos ambientais de sumidouros → Negativo
4. Corrosão de armadura da laje perto piscina → Negativo

64

Terceira Lição

- ✓ Mantenha visão crítica das notícias na mídia por mais que pareçam verdadeiras
- ✓ *Por exemplo no caso do Palace II noticiaram que o concreto tinha conchinhas do mar na massa*
- ✓ *No caso do colapso do Ed. Paes de Almeida noticiaram que estourou um bujão de gás*
- ✓ *No caso do Grenfell Tower (Maria Angélica) os bombeiros mandaram os condôminos permanecerem nos apartamentos. Resultado: 72 mortos*

65

Hipóteses do “Gatilho”

→ Fissura + corrosão → muro de divisa

→ Punção + corrosão → laje recreação

→ Recalque diferencial → punção

66

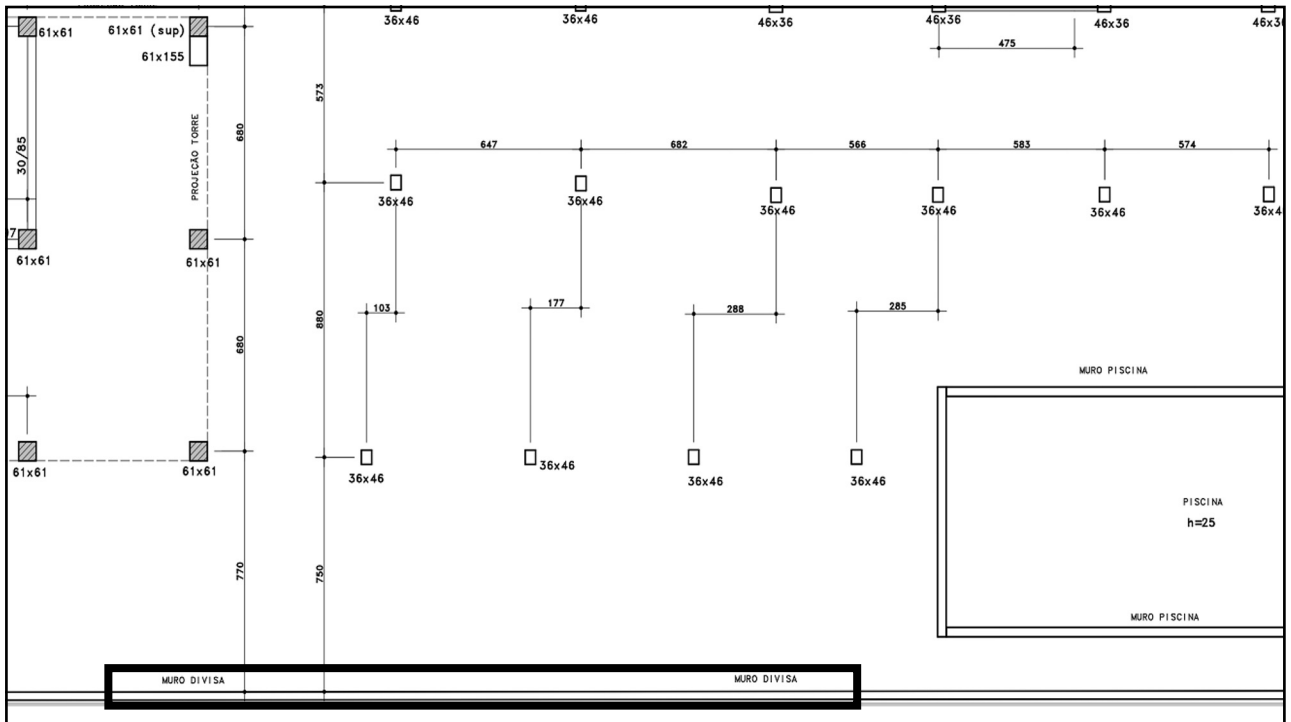

67

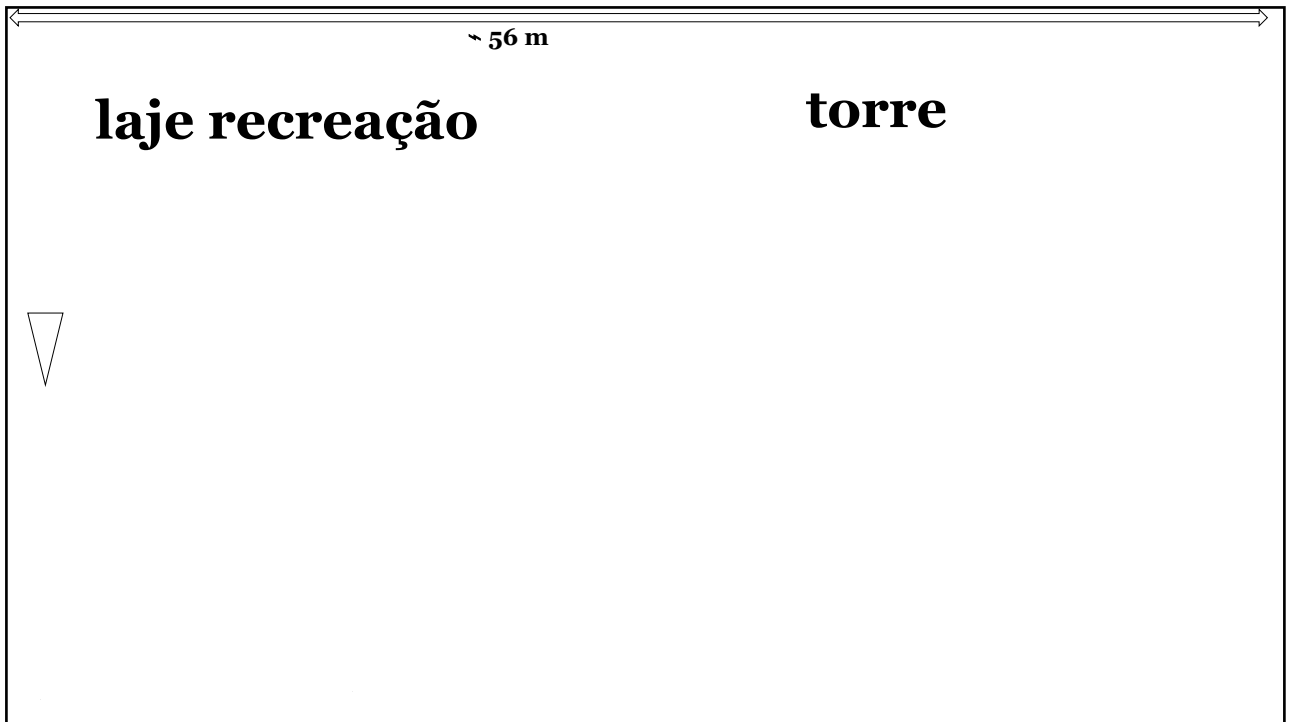

68

Fisuración bajo Carbonatación y/o Cloruro

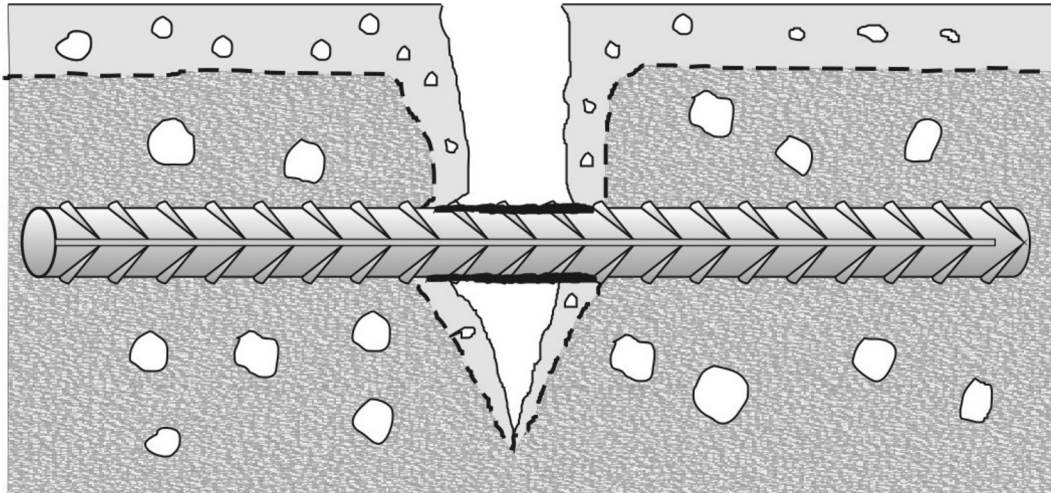

w_k ânodo pequeño vs cátodo enorme

69

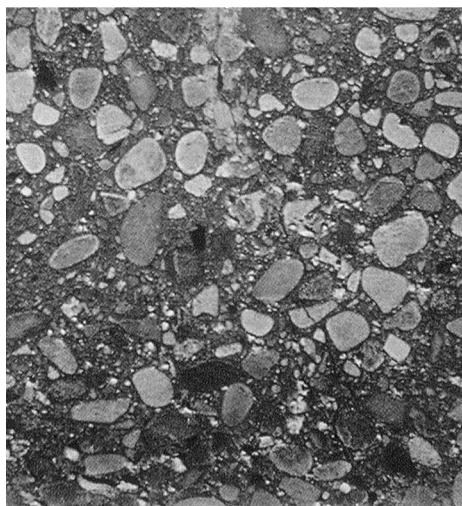
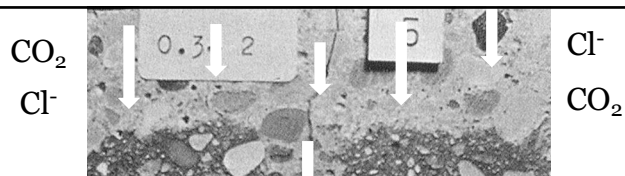

70

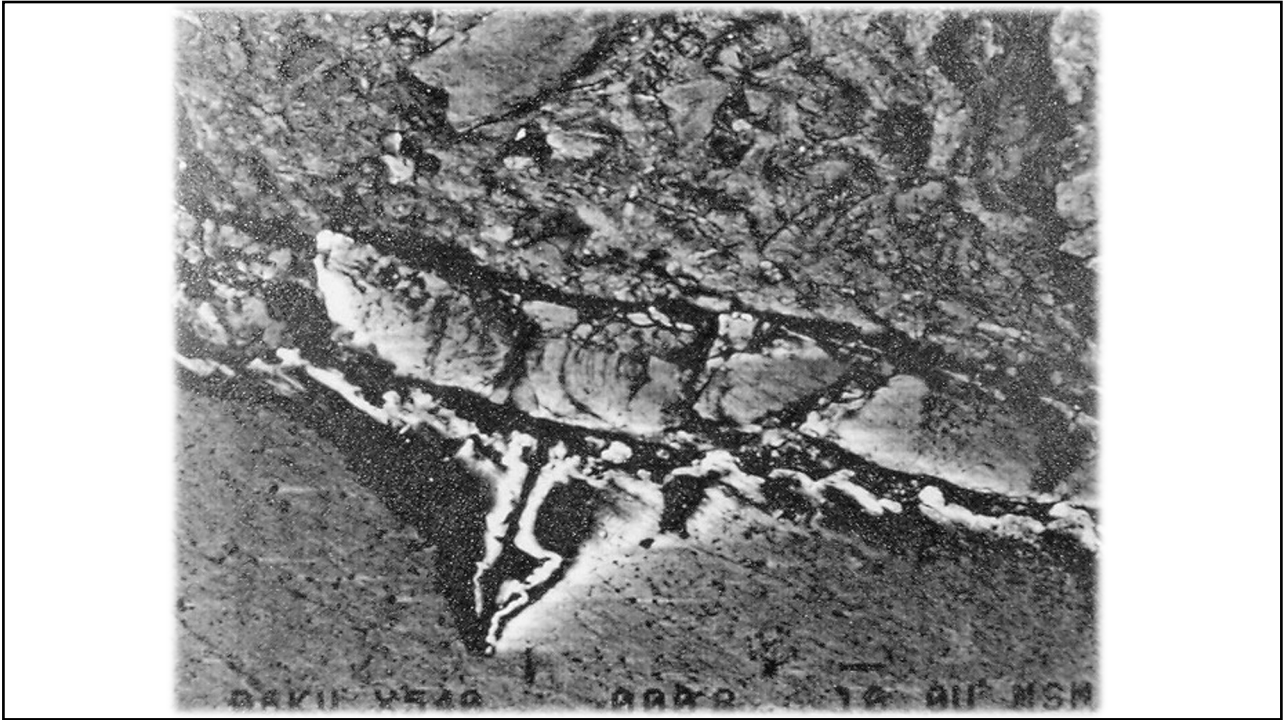

71

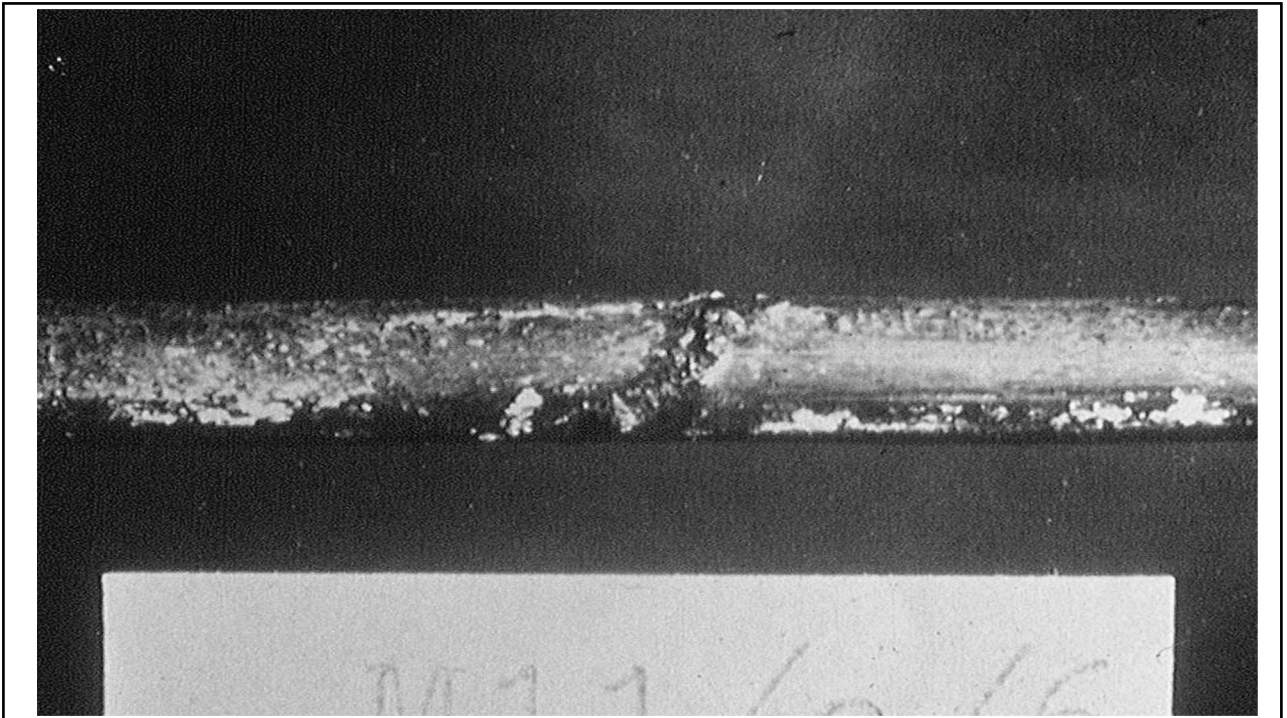

72



73



74



75



76



77



78



79



80



81

**Thursday
April 21, 2022**

**MIAMI
HERALD**



A photo of the Champlain Towers South pool deck shows the slab disconnected from the southern wall during the June 24 collapse. Damage in the failure plain is not uniform, indicating pre-existing damage to portions of the slab at the connection, according to engineer Dawn Lehman. Robert Lisman

<https://www.miamiherald.com/news/special-reports/surfside-investigation/article260418037.html>

82

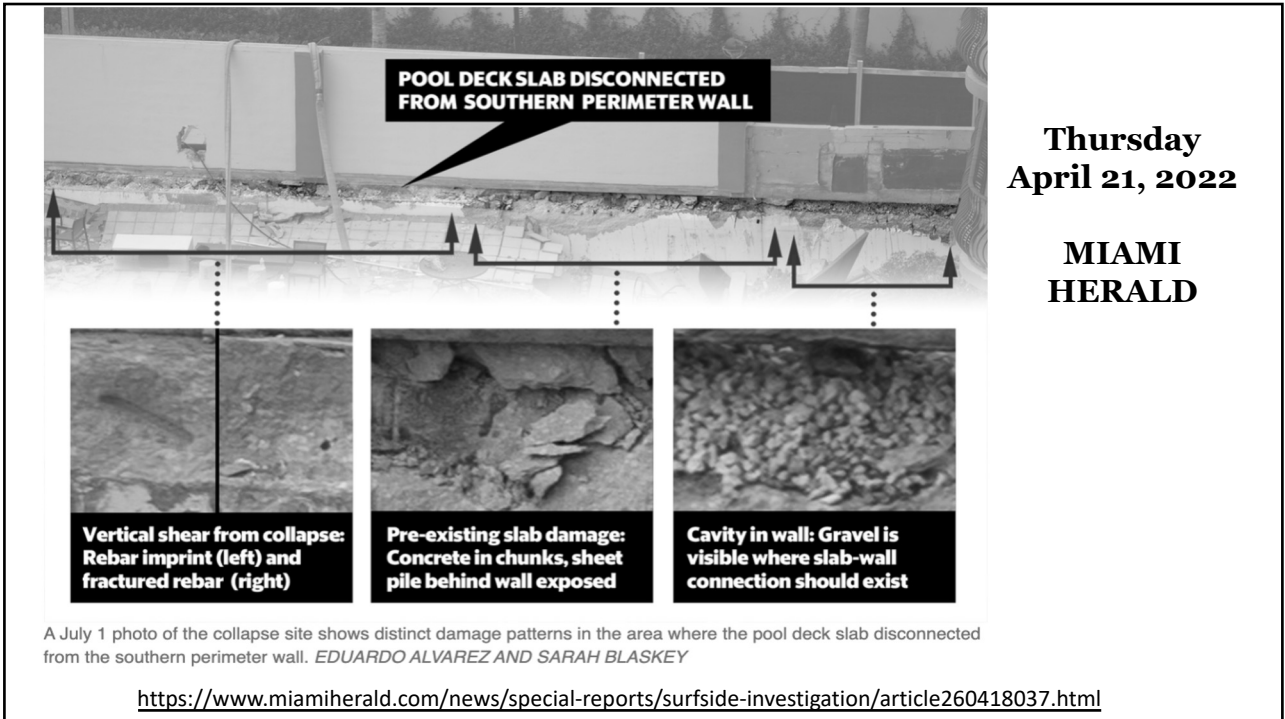

83

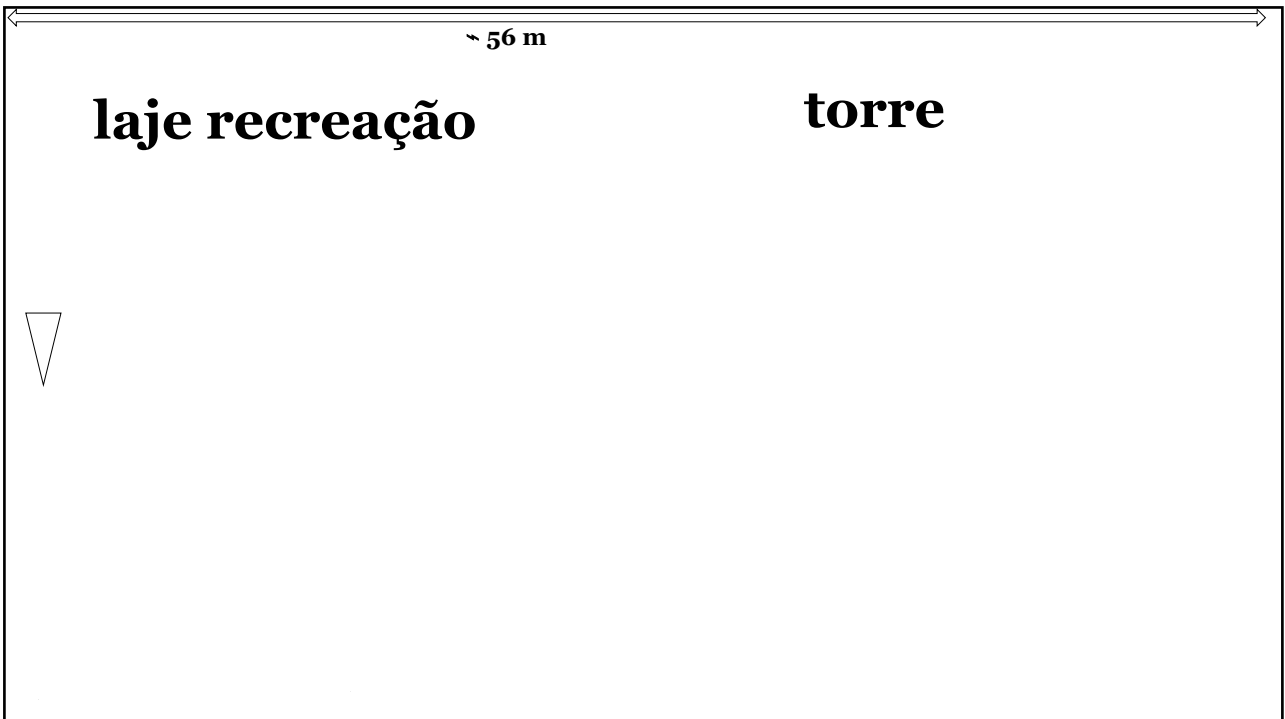

84



October 8, 2018

Champlain Towers South
8777 Collins Avenue
Surfside, FL 33154

Attention: Ms. Maggie Manrara
Treasurer

**Re: Champlain Towers South Condominium
Structural Field Survey Report
MC Job# 18217**

Dear Ms. Manrara:

Morabito Consultants, Inc. (MC) is pleased to submit this structural engineering report of the Field Survey completed at the existing Champlain Towers South Condominium Complex (CTS) in Surfside, FL. The scope of this project includes a review of the existing 12 story plus penthouse 136-unit residential building, below-grade parking garage and at-grade exterior entrance drive, pool and recreation area. MC reviewed a representative sample of ~68 condominium units (half of the total units found in the building) along with the roof, exterior facade (observed from the balconies surveyed), parking garage,

85

https://www.townofsurfsidefl.gov/docs/default-source/default-document-library/town-clerk-documents/champlain-towers-south-public-records/8777-collins-ave---structural-field-survey-report.pdf?sfvrsn=882a1194_2

" The Pool Deck and Entrance Drive areas were reviewed

...

Many of the existing pavers on the pool deck are cracked

...

The joint sealant was observed to be beyond its useful life and are in need to complete replacement

...

The failed waterproofing is causing major structural damage to the concrete structural slab below these areas "

86

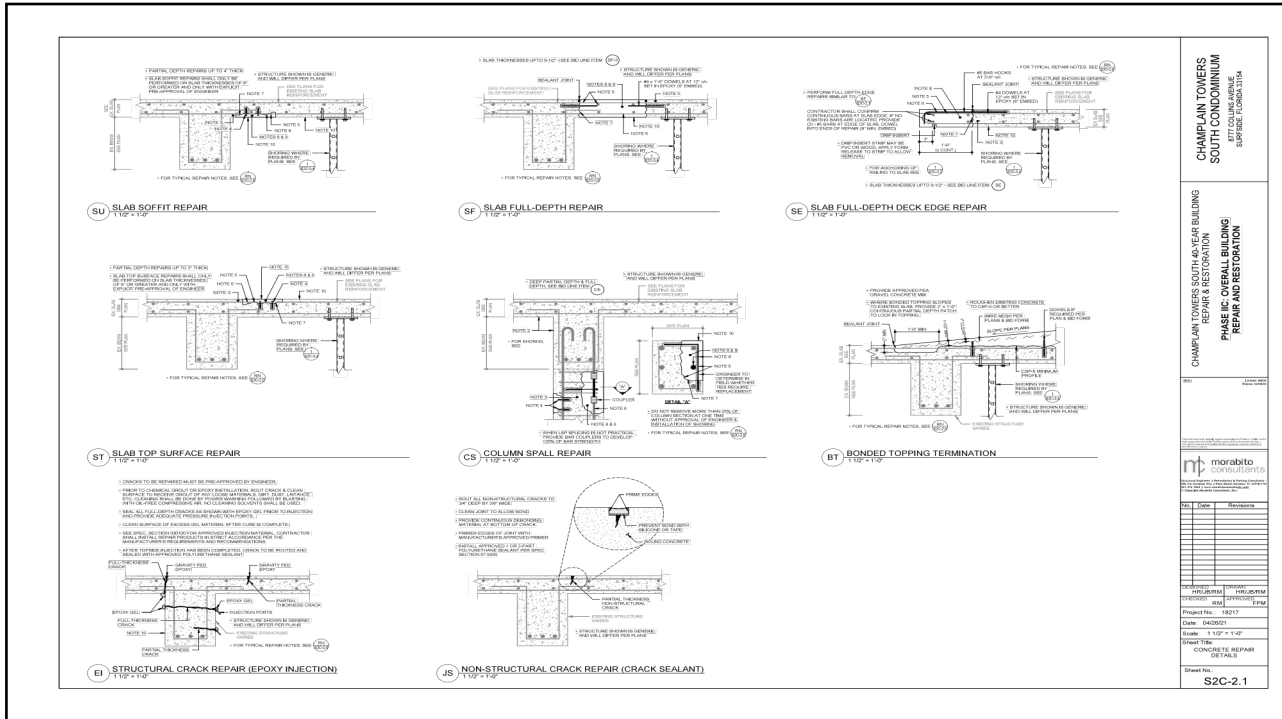

CHAMPLAIN TOWERS SOUTH CONDOMINIUM
8777 COLLEGE AVENUE
BURBANK, FLORIDA 33154

CHAMPLAIN TOWERS SOUTH 40-YEAR BUILDING
REPAIR & RESTORATION
PHASE IIC - OVERALL BUILDING
REPAIR AND RESTORATION

Project No. 18217
Date: 04/09/21
Scale: 1/2" = 1'-0"
Sheet Title: CONCRETE REPAIR DETAILS
Sheet No. S2C-2.1

87

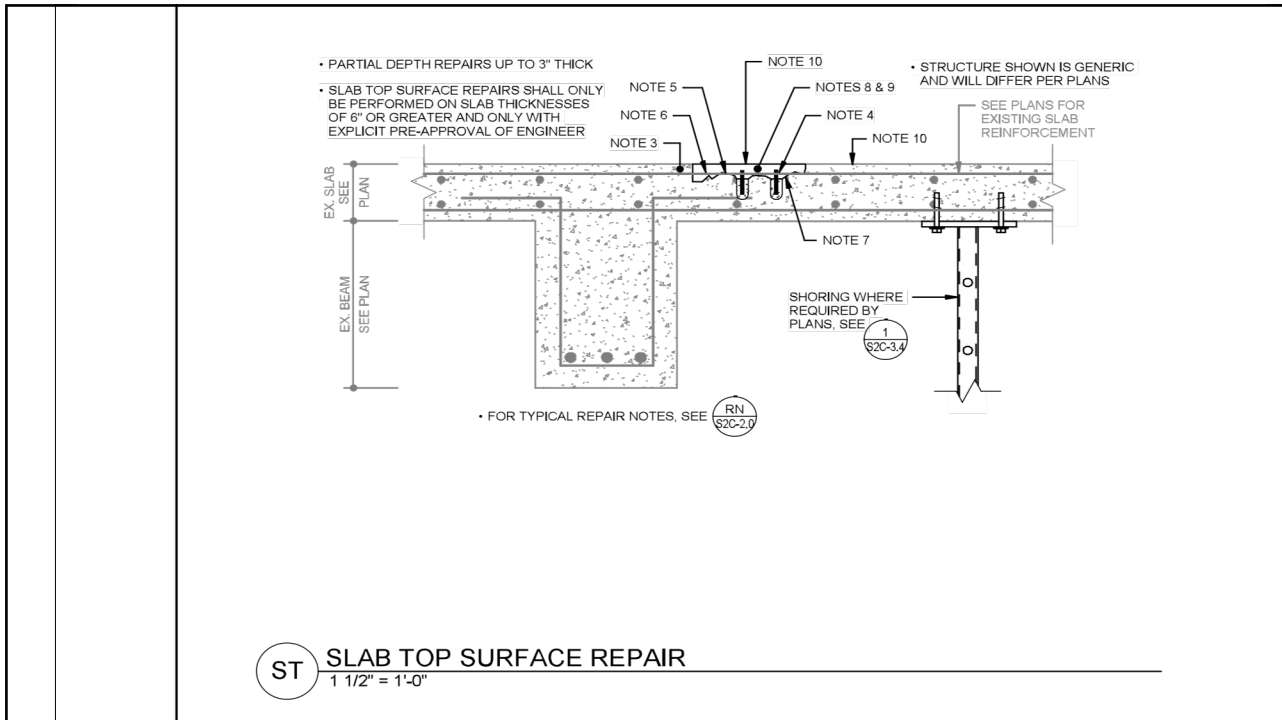

88

- ❖ Pacometria – posição das armaduras
- ❖ Esclerometria - dureza superficial
- ❖ Ultrassom – ninhos de concretagem
- ❖ Testemunhos - f_c e modulo do concreto
- ❖ Cobrimento
- ❖ Espessura de carbonatação
- ❖ Presença e perfil de cloreto
- ❖ Geometria de fissuras
- ❖ **Identificação de áreas problemáticas**



89

Quarta Lição

- ✓ É fundamental proceder a uma inspeção correta e detalhada, realizada por profissionais experientes e certificados que saibam identificar os pontos críticos da estrutura que está sendo inspecionada

“...tudo o que diz a Red DURAR, a ALCONPAT, os CTs do IBRACON, ABNT, ... anamenese, ensaios, conhecimento do projeto estrutural, cloretos, prospecção...”

90

Hipóteses do “Gatilho”

→ Fissura com corrosão no muro de divisa OK

→ Punção + corrosão

→ Recalque diferencial

91



92



93

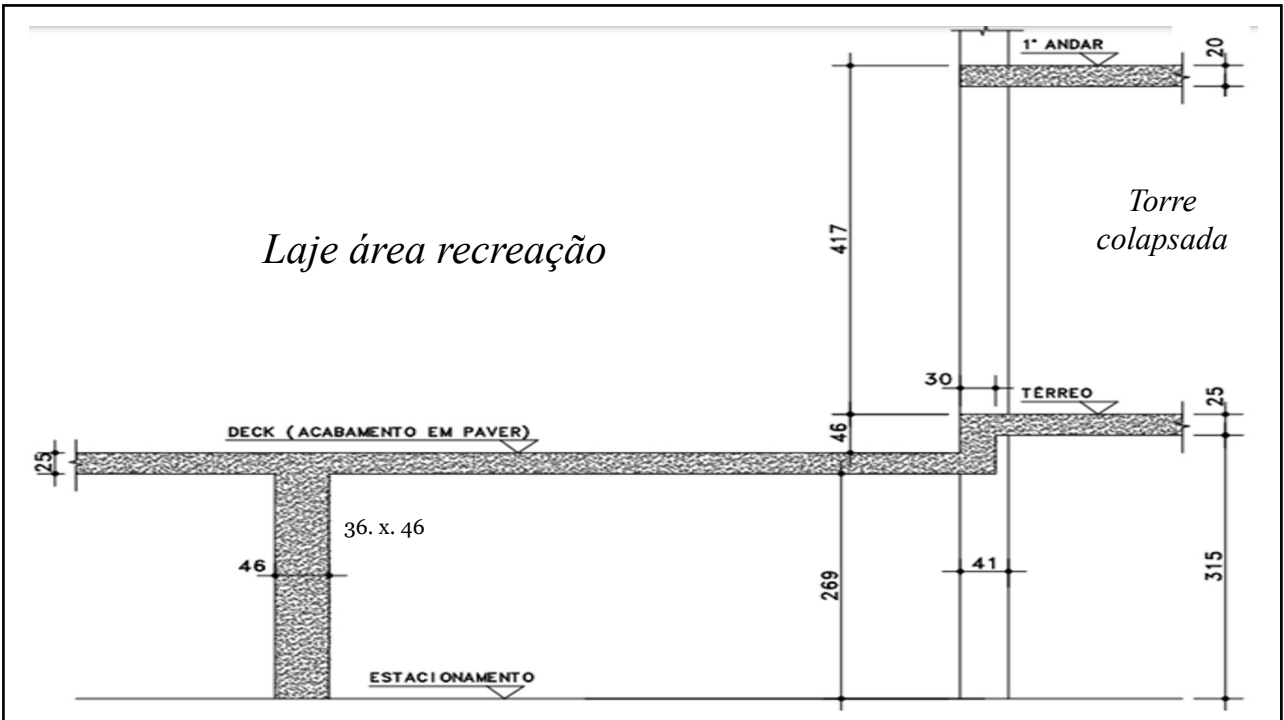

94

ARMADURA LAJE RECREAÇÃO com TÉRREO

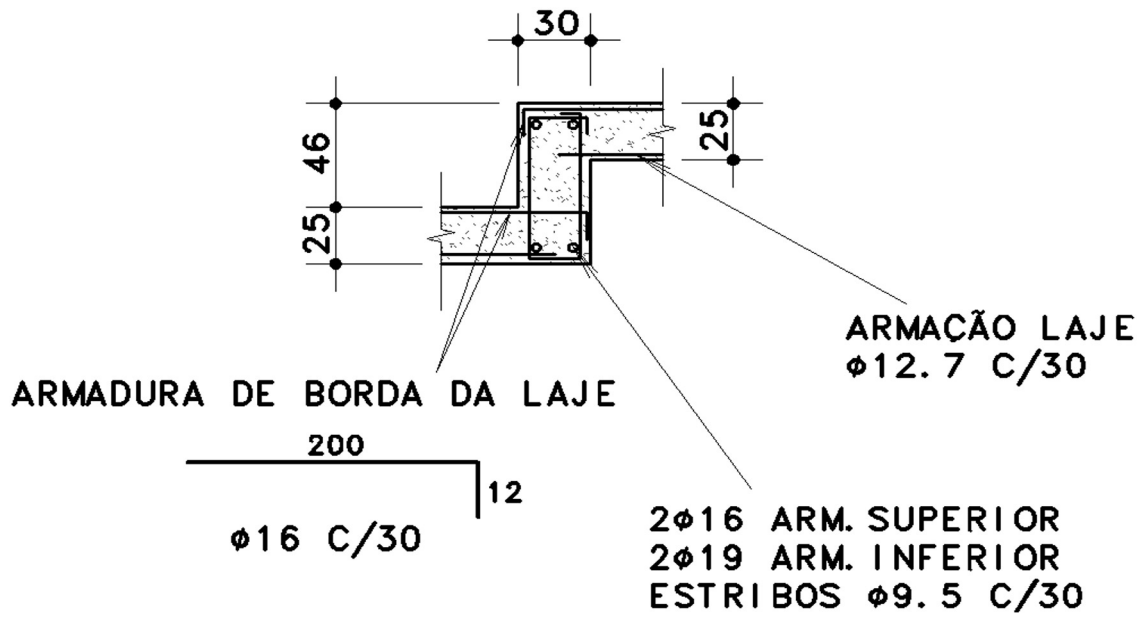

95

Armadura SUPERIOR pilares 36x46 cm
Laje área lazer, plana, sem capitel

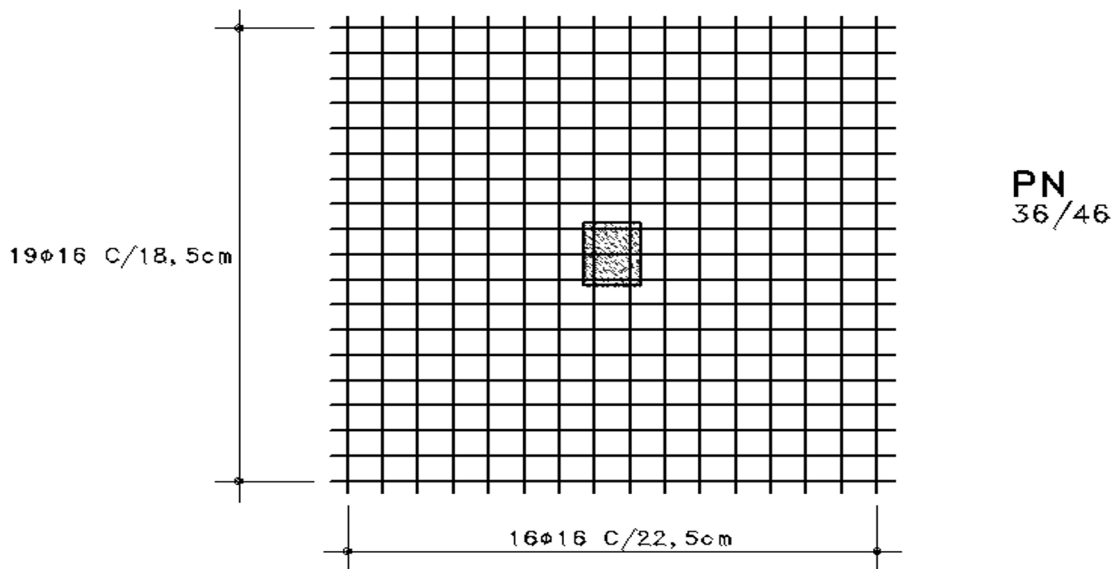

96

Laje Recreação/Estacionamento → Punção

$e_{\text{nominal}} = 25 \text{ cm} \rightarrow \text{altura útil} \rightarrow d = 22 \text{ cm}$

Carga peso próprio = 625 kgf/m²

Carga permanente = 325 kgf/m² Total : 1.200 kgf/m²

Carga acidental = 250 kgf/m²

“área de influencia” ou modelo

Carga no pilar = 50.000 kgf (50tf)

Nota: não foi considerado efeito de momento na cabeça do pilar, nem flexão, portanto uma verificação aproximada da realidade

97

Laje Recreação/Estacionamento → Punção

$f_{ck,laje} = 27,6 \text{ MPa (N/mm}^2\text{)}$

$f_{ck,pilar} = 41,4 \text{ MPa (N/mm}^2\text{)}$

Armadura em x = $\phi 16$ cada 15,3cm $\rho_x = 0,60\%$

Armadura em y = $\phi 16$ cada 17,5cm $\rho_y = 0,52\%$

$$\rho = \sqrt{\rho_x * \rho_y}$$

Taxa de Armadura = 0,0056 = 0,56%

98

Laje Recreación/Estacionamiento → Punção *resumo*

$$f_{ck,laje} = 27,6 \text{ MPa (N/mm}^2\text{)}$$

$$f_{ck,pilar} = 41,4 \text{ MPa (N/mm}^2\text{)}$$

$$\text{Taxa armadura} = \rho = 0,0056 = 0,56\%$$

$$\text{Normal solicitante} \rightarrow F_{sd} = 500 * \gamma_f \quad (\text{kN})$$

$$\text{Perímetro crítico} \rightarrow \mu = 440 \text{ cm}$$

$$\text{Altura útil } d = 22 \text{ cm}$$

$$C1 = 36 \text{ cm} \quad C2 = 46 \text{ cm}$$

Contorno C'

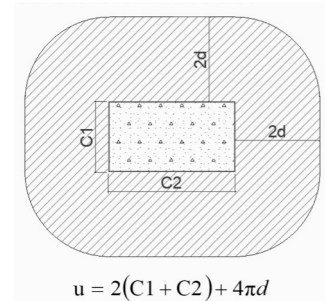

99

apartado 20.12

“Punzonamiento”

pág. 418 a 422

Hormigón Armado

14^o Edición

Refere-se a EHE

Publicada em 2000

Pedro Jiménez Montoya

Álvaro García Meseguer

Francisco Morán Cabre



100

EHE 2000 → Punção

$$\tau_{Rd} = 0,12 * \left(1 + \sqrt{\frac{200}{d}}\right) * \sqrt[3]{(100 * \rho * f_{ck})}$$

Contorno C'

$$\tau_{sd} = \frac{\beta * F_{sd}}{\mu * d}$$



101

Norma Espanhola EHE 2000 → Punção

$$\tau_{Rd} = 0,12 * \left(1 + \sqrt{200/220}\right) * (100 * 0,0056 * 27,6)^{1/3} = \mathbf{0,58 \text{ MPa}}$$

$$\tau_{Rd} = 0,12 * \left(1 + \sqrt{200/220}\right) * (100 * 0,0056 * 41,4)^{1/3} = \mathbf{0,63 \text{ MPa}}$$

$$\tau_{sd} = \frac{\beta * F_{sd}}{u * d} = \frac{1,15 * 500kN * \gamma_f}{440cm * 22cm} = 0,59 \text{ MPa} * y_f$$

102

EHE 2000 → Punção

$$\tau_{Sd} < \tau_{Rd}$$

$$\tau_{Rd} = \mathbf{0,58 \text{ a } 0,63 \text{ MPa}}$$

$$\tau_{Sd} = \mathbf{0,59 * \gamma_f}$$

$$\gamma_f = \mathbf{0,98 \text{ a } 1,07}$$

(1,5 ?!)

103

NBR 6118:2014 Cálculo da Solicitante à Punção

Pilar interno, carregamento simétrico (sem efeito de momento)

$$\begin{aligned} \tau_{Rd} &= 0,13 * \left(1 + \sqrt{20/d}\right) * (100 * \rho * f_{ck})^{1/3} = \\ &= 0,13 * \left(1 + \sqrt{20/22}\right) * (100 * 0,56\% * 27,6)^{1/3} = 0,63 \text{ MPa} \\ &41,4 \rightarrow 0,72 \text{ MPa} \end{aligned}$$

$$\tau_{Sd} = \frac{F_{Sd}}{u \times d} = \frac{500kN * \gamma_f}{440cm * 22cm} = 0,52 \text{ MPa} * \gamma_f$$

$$\gamma_f = \mathbf{1,21 \text{ a } 1,38}$$

(1,4 ?!)

104

ACI 318:14 Punção

$$\tau_{Rd} = 0,25 * \sqrt{f_{ck}}$$

$$\tau_{Rd} = 0,25 * \sqrt{27,6} = 1,31 \text{ MPa}$$

$$\tau_{Rd} = 0,25 * \sqrt{41,4} = 1,60 \text{ MPa}$$

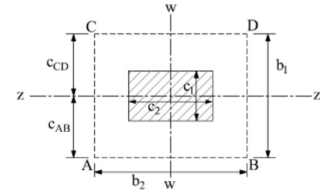

$$\tau_{sd} = \frac{F_{sd}}{u_1 * d} + \frac{\gamma_v * M_{sd} * b_1 / 2}{J_c}$$

$$\tau_{sd} = \frac{F_{sd}}{u_1 * d} = \frac{500 \text{ kN} * y_f}{252 \text{ cm} * 22 \text{ cm}} = 0,90 \text{ MPa} * y_f$$

105

ACI 318:14 Punção

$$\tau_{Rd} = 1,31 \text{ MPa}$$

$$\tau_{Rd} = 1,60 \text{ MPa}$$

$$\tau_{sd} = 0,90 \text{ MPa} * y_f$$

(1,4 ?!)

$$y_f = 1,45 \text{ a } 1,77$$

Obs.: ACI é muito diferente. Neste caso não passa a armadura de flexão, por exemplo.

106

fib Model Code:2010 Punção

$$F_{Rd} = k_{\Psi} * \frac{\sqrt{f_{ck}}}{\gamma_c} * b_0 * d$$

$$F_{Rd} = 0,214 * \frac{\sqrt{27,6}}{1,5} * 2100mm * 220mm = 347 \text{ kN}$$

$$F_{Rd} = 0,214 * \frac{\sqrt{41,4}}{1,5} * 2100mm * 220mm = 424 \text{ kN}$$

$$F_{Sd} = 500 \text{ kN} * y_f$$

107

fib Model Code:2010 Punção

$$F_{Rd} = 347 \text{ kN}$$

$$F_{Rd} = 424 \text{ kN}$$

$$F_{Sd} = 500 * y_f$$

(1,5 ?!)

$$\gamma_f = 0,69 \text{ a } 0,85$$

Obs.: comparativo de esforços resistente versus solicitante.

108

ACI 318:	$\gamma_f = 1,45 \text{ a } 1,77$
fib Model Code:2010:	$\gamma_f = 0,69 \text{ a } 0,85$
Norma Espanhola EHE.2000:	$\gamma_f = 0,98 \text{ a } 1,07$
NBR 6118:2014 → contorno C'	$\gamma_f = 1,21 \text{ a } 1,38$

+retração + efeitos térmicos + recalque diferencial + corrosão

109

Quinta Lição

- ✓ As normas não são iguais, evite usar só um pedaço de uma misturado com outra
- ✓ É essencial proceder com uma revisão por pares do projeto estrutural antes de começar a construir, realizada por especialistas que saibam identificar os pontos críticos da estrutura.

“...norma brasileira ABNT NBR 6118 prescreve ATP...”

110

Hipóteses do “Gatilho”

→ Fissura + corrosão no muro de divisa - OK

→ Punção + corrosão - OK

→ Recalque diferencial + corrosão

111

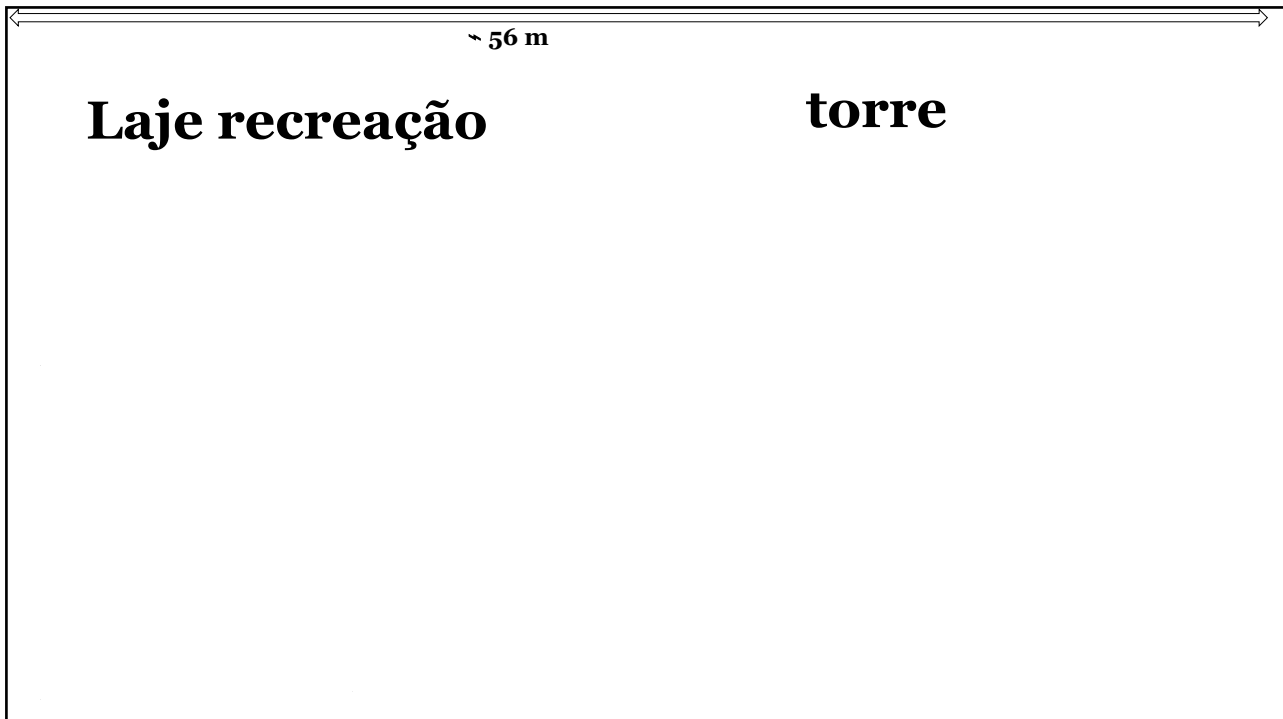

112

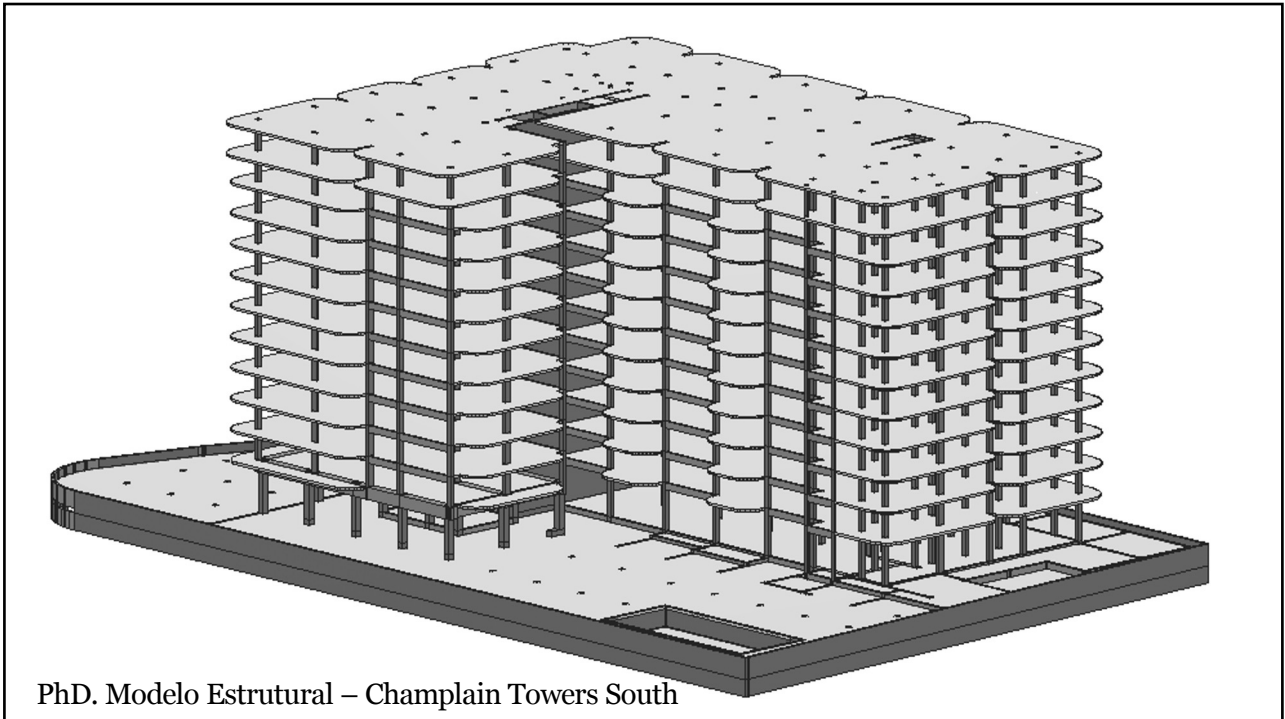

113

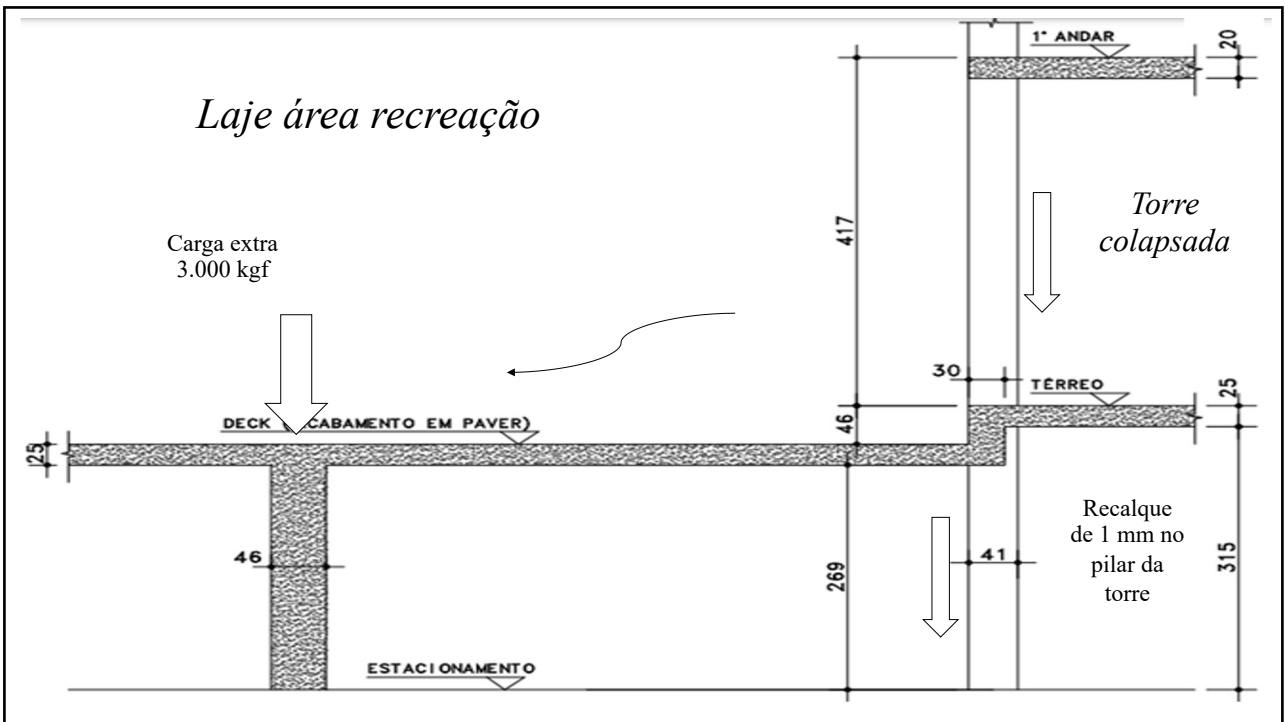

114

EHE 2000 Recalque Diferencial

$$\gamma_f = 0,69; 0,98; 1,21 \text{ e } 1,45 = 1,09$$

Carga nos pilares = 50.000 kgf

Recalque 1 mm \rightarrow carga extra \approx 3.000 kgf

$$\gamma_f = 1,02$$

115

EHE 2000 Recalque Diferencial

$$\gamma_f = 0,69; 0,98; 1,21 \text{ e } 1,45 = 1,09$$

Carga no Pilar = 50.000 kgf

Recalque 2 mm \rightarrow carga extra \approx 6.300 kgf

$$\gamma_F = 0,97$$

116



117

O que recomendar à Champlain Towers North ??

1. Proibir estacionar carro
2. Revisar projeto
3. Inspeccionar fisuras (muro e cabeça pilar)
4. Promover junta dilatação (consoles)
5. Verificar conceito de robustez

118



Shoring is visible around at least 11 columns at Champlain Towers North, sister building to the Champlain Towers South condo that collapsed in June 2021.

119

armaduras
típicas de
punção

120

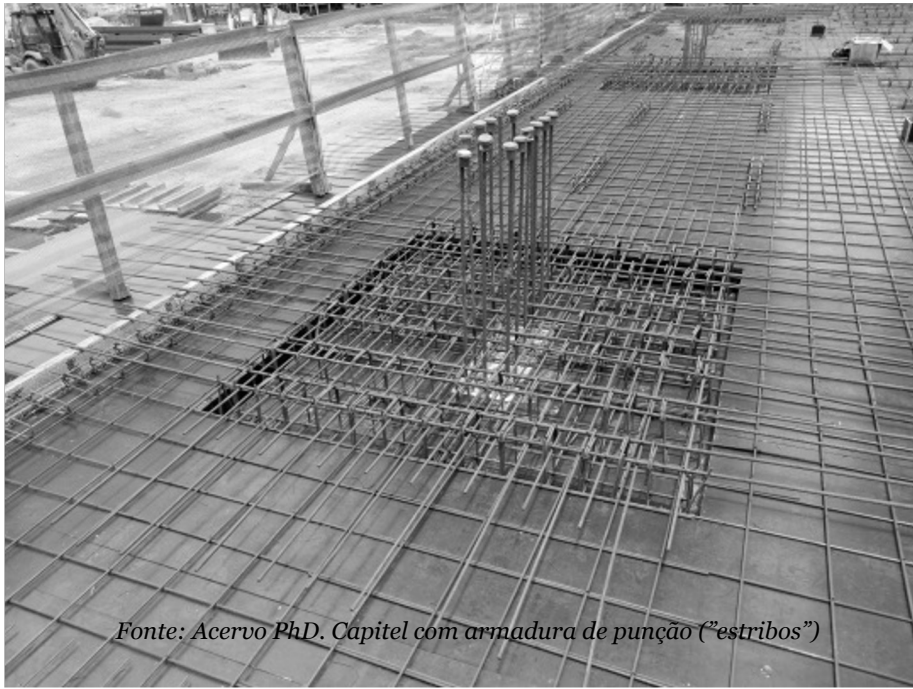

Fonte: Acervo PhD. Capitel com armadura de punção ("estribos")

121

CORTE TÍPICO NAS ARMAÇÕES DE PUNÇÃO E COLAPSO PROGRESSIVO (SEM CAPITEL)

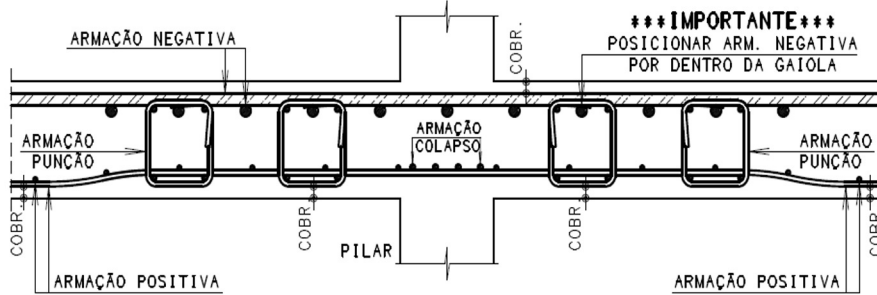

DETALHE DE AMARRAÇÃO NOS ESTRIBOS

AS BARRAS LONGITUDINAIS DEVEM ESTAR RIGOROSAMENTE ENCOSTADAS E AMARRADAS NOS QUATRO CANTOS DOS ESTRIBOS

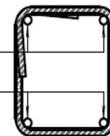

Fonte: Ricardo França & Associados

122



Figura 5.8
ETAPA 1 | Posicionamento dos conectores/studs

Fonte: Manual de Boas Práticas. Montagem das Armaduras de Estruturas de Concreto Armado. Jorge Nakashima (Sartoro) & Larissa Arakawa Martins, 2021

123

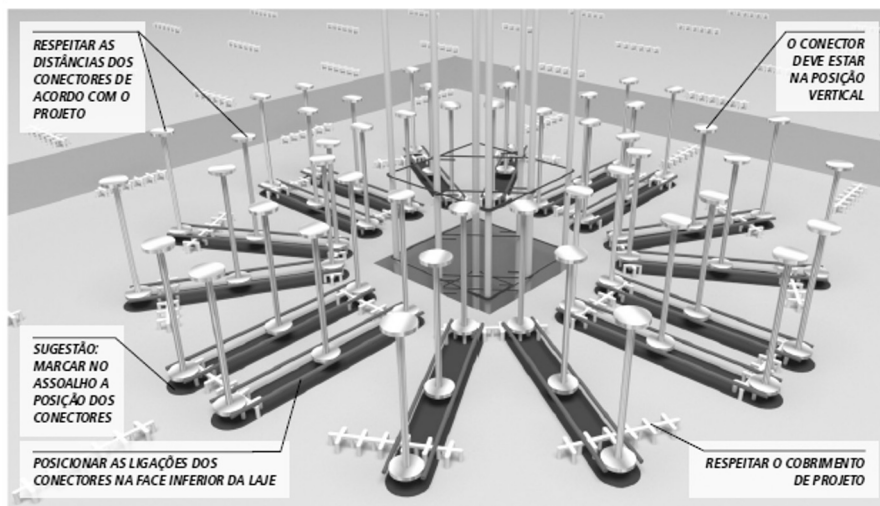
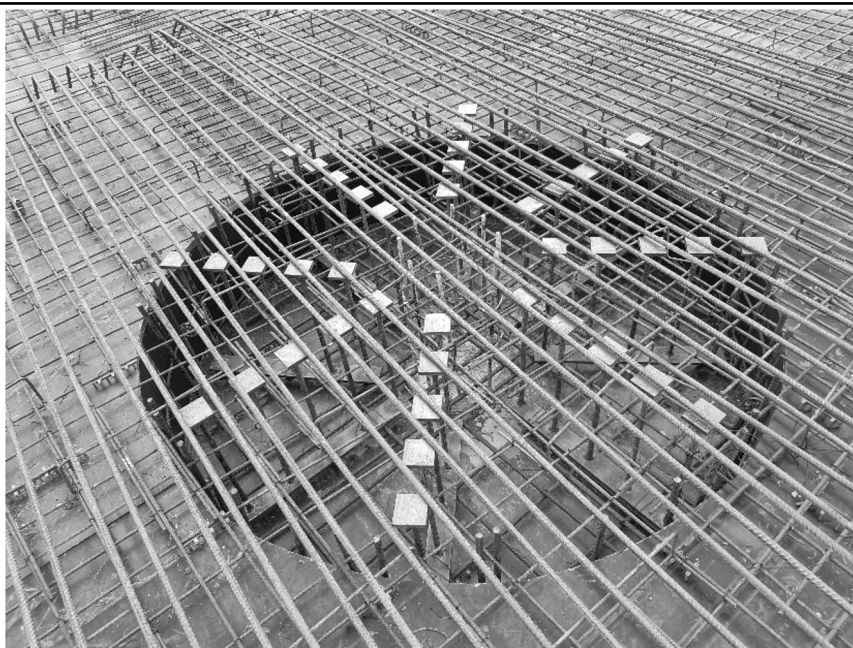

Fonte: Acervo PhD. Capitel com armadura de punção (“studs”).

124

Lições Aprendidas

- ❖ Transparência para a Sociedade e valorização da Engenharia
- ❖ ATP (análise técnica de projeto, revisão por pares)
- ❖ ATO (acompanhamento técnico de obra, supervisão e controle)
- ❖ ATU (acompanhamento técnico do uso, inspeção periódica)
- ❖ Obras de manutenção preventiva e corretiva – vida útil
- ❖ Cuidado com água e não menosprezar corrosão
- ❖ Escolher profissionais bem preparados (certificação, CV)

125

**Muito
obrigado!**



126